

PRICE LISTS

SUGGESTED LIST PRICES

GASOLINE AND DIESEL BASIC ENGINES



KOHLER
ENGINES

EFFECTIVE SEPTEMBER 1, 2010

Contents

Description	Page
Gasoline Basic Engines	3-40
Courage XT-Series Engines.....	3-5
Courage Small Horizontal Engines.....	6
Courage Single Engines	7
Courage Twin Engines	8
Courage Pro Twin Engines.....	9
Command PRO Vertical Shaft Engines.....	10-12
Command PRO Small Horizontal Shaft Engines.....	13-20
Command Pro Horizontal Shaft Engines	21-34
Command Engines.....	35-39
Aegis Horizontal Shaft Engines	40
Diesel Basic Engines	41-51
Diesel Air-Cooled	41-45
Diesel Liquid-Cooled	46-51
Evap Cross Reference Courage and Command.....	52-53

Prices shown are for Kohler Basic Engines. All other specification prices are available on request from Kohler Co. All prices are in U.S. Dollars, FOB factory, Kohler, Wisconsin, U.S.A., and are subject to change without notice. All engine specifications on this price list are subject to change without notice.

Gasoline engine horsepower ratings exceed Society of Automotive Engineers Small Engine Test Code J1940. Actual engine horsepower is lower and affected by, but not limited to, accessories (air cleaner, exhaust, charging, cooling, fuel pump, etc.), application, engine speed, and ambient operating conditions (temperature, humidity, and altitude). For more information, contact Kohler Co. Engine Engineering Department.

Diesel engine horsepower ratings are provided according to ISO 1585. The diesel automotive power rating is according to ISO 1585. Actual diesel engine horsepower is lower and affected by, but not limited to, accessories (air cleaner, exhaust, charging, cooling, etc.), application, engine speed, and ambient operating conditions (temperature, humidity, and altitude). For more information, contact Kohler Co. Engine Engineering Department.

Miscellaneous Information:

1. All crankshafts rotate counterclockwise when viewed toward the PTO face.

COURAGE XT-Series XT-6 (Vertical Shaft) Single Cylinder

Description	HP	Model	Spec. No.	List Price	Approx. Ship Wt. (lb.)
Standard Features:					
<ul style="list-style-type: none"> • Overhead Valve • Cast Iron Cylinder Bore • Flywheel Ball Upper Main Bearing • 149 cc Displacement • Net Peak Torque - 6.3 ft. lbs. @ 2600 rpm • Net Horsepower - 3.8 hp @ 3600 rpm • Splash Lubrication • Accu-Fill™ Fuel Tank • 1.1 Liter Fuel Tank • ¼ Turn, Easy Access Extended Yellow Dipstick • Light Weight Flywheel for Lawnmowers • Fixed Speed @ 3100 rpm • Internally Vented Carburetor • Automotive Style Pleated Air Filter with Foam Precleaner • Flywheel Brake • Easy-Pull Recoil Starter with Ergonomic Handle • Smart-Choke™, easy, no prime starting • Electronic Ignition • Front Exit Muffler with Guard • Internal Fuel Filter • Black Engine Cover and 6-position recoil • Resistive Spark Plug • Crankshaft - 25 mm Diameter x 3-5/32" PTO Length, 1/4" Full Key, 2 #505 Woodruff Slots, Drilled and Tapped 3/8"-24 UNF • SAE J609 Mounting Flange E (8" dia. BC) • EPA Phase II, CARB Tier II Exhaust Compliant • RFI Compliant 	3.8	XT-6	XT149-0201		30
Standard Features Plus:					
<ul style="list-style-type: none"> • Crankshaft-7/8" (22.225 mm) Diameter x 3 5/32" (80.1688 mm), 2-#505 Woodruff Key Slots, 3/16" Full Key, Drilled and Tapped 3/8"-24 UNF 	3.8	XT-6	XT149-0202		30
Standard Features Plus:					
<ul style="list-style-type: none"> • Crankshaft-7/8" (22.225 mm) Diameter x 3 5/32" (80.1688 mm), 2-#505 Woodruff Key Slots, 3/16" Full Key, Drilled and Tapped 3/8"-24 UNF • Electric Start • Side Discharge Muffler • Remote variable speed 1800-3300 rpm with choke and kill incorporated • Utility Model • No foam precleaner 	3.8	XT-6	XT149-0203		30

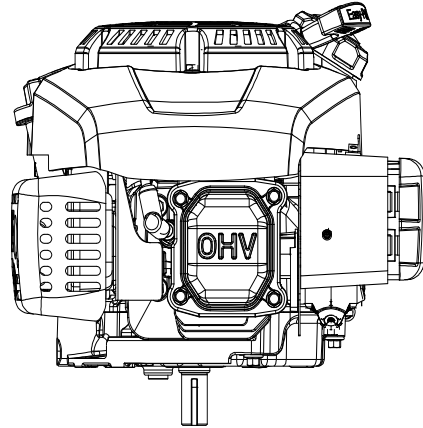

Note: Contact your source of supply for pricing.

**COURAGE XT-Series
XT-7 (Vertical Shaft) Single Cylinder**

Description	HP	Model	Spec. No.	List Price	Approx. Ship Wt. (lb.)
Standard Features:					
<ul style="list-style-type: none"> • Overhead Valve • Cast Iron Cylinder Bore • Flywheel Ball Upper Main Bearing • 173 cc Displacement • Net Peak Torque - 7.3 ft. lbs. @ 2600 rpm • Net Horsepower - 4.8 hp @ 3600 rpm • Splash Lubrication • Accu-Fill™ Fuel Tank • 1.4 Liter Fuel Tank • ¼ Turn, Easy Access Extended Yellow Dipstick • Light Weight Flywheel for Lawnmowers • Fixed Speed @ 3100 rpm • Internally Vented Carburetor • Automotive Style Pleated Air Filter with Foam Precleaner • Flywheel Brake • Easy-Pull Recoil Starter with Ergonomic Handle • Smart-Choke™, easy, no prime starting • Electronic Ignition • Front Exit Muffler with Guard • Internal Fuel Filter • Black Engine Cover and 6-position recoil • Resistive Spark Plug • Crankshaft - 25 mm Diameter x 3-5/32" PTO Length, 1/4" Full Key, 2 #505 Woodruff Slots, Drilled and Tapped 3/8"-24 UNF • SAE J609 Mounting Flange E (8" dia. BC) • EPA Phase II, CARB Tier II Exhaust Compliant • RFI Compliant 	4.8	XT-7	XT173-3204	30	
Standard Features Plus:					
<ul style="list-style-type: none"> • Crankshaft-7/8" (22.225 mm) Diameter x 3 5/32" (80.1688 mm), 2-#505 Woodruff Key Slots, 3/16" Full Key, Drilled and Tapped 3/8"-24 UNF • 9 o'clock recoil position, (12 o'clock valve cover) • Heavy Flywheel • Primer Bulb • Fixed Speed at 3600RPM • Rocker Switch Kill • Not RFI Compliant • No Foam Precleaner 	4.8	XT-7	XT173-0202	30	

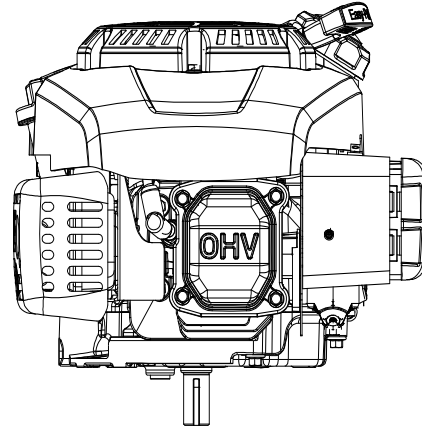

Note: Contact your source of supply for pricing.

**COURAGE XT-Series
XT-7 (Vertical Shaft) Single Cylinder**

Description	HP	Model	Spec. No.	List Price	Approx. Ship Wt. (lb.)
Standard Features Plus:					
<ul style="list-style-type: none"> • Crankshaft-7/8" (22.225 mm) Diameter x 3 5/32" (80.1688 mm), 2-#505 Woodruff Key Slots, 3/16" Full Key, Drilled and Tapped 3/8"-24 UNF 	4.8	XT-7	XT173-3203		30
Standard Features Plus:					
<ul style="list-style-type: none"> • Crankshaft-7/8" (22.225 mm) Diameter x 3 5/32" (80.1688 mm), 2-#505 Woodruff Key Slots, 3/16" Full Key, Drilled and Tapped 3/8"-24 UNF 	4.8	XT-7	XT173-3205		30
Standard Features Plus:					
<ul style="list-style-type: none"> • Crankshaft-7/8" (22.225 mm) Diameter x 3 5/32" (80.1688 mm), 2-#505 Woodruff Key Slots, 3/16" Full Key, Drilled and Tapped 3/8"-24 UNF • Heavy Flywheel for utility applications • Remote Manual Choke • Remote Variable Speed 1800-3300 rpm • Remote low speed shutdown • Side discharge muffler 	4.8	XT-7	XT173-3206		30
Standard Features Plus:					
<ul style="list-style-type: none"> • Stepped Blade Brake Clutch (BBC) Crankshaft • Heavy Flywheel • Ignition kill lead for remote shutdown 	4.8	XT-7	XT173-3207		30

Note: Contact your source of supply for pricing.

**COURAGE SMALL HORIZONTAL
6.5 HP (Horizontal Shaft) Single Cylinder**

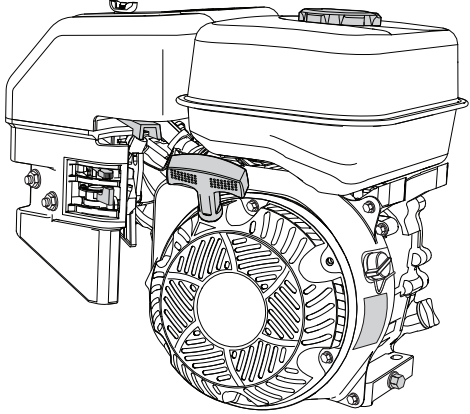
Description	HP	Model	Spec. No.	List Price	Approx. Ship Wt. (lb.)
Standard Features:					
<ul style="list-style-type: none"> • Overhead Valve Design • Electronic Ignition • Dual Element Air Cleaner • Dual Oil Fill Locations • Dual Oil Drain • Cast Iron Cylinder Liner • 3.6 L Metal Fuel Tank with Strainer • Fuel Shut-off Valve • Engine Mounted Throttle and Choke Controls, Remote Throttle Ready • Oil Sentry™ Switch Installed (No Light) • Dual Ball Bearings, PTO and Flywheel • Metal Blower Housing • Indexable Recoil Starter • Crankshaft - 0.75" (19.05 mm) Diameter x 2.42" (61.47 mm) PTO Length, Tapped 5/16-24 UNF • PTO Face - 3.625" (92.08 mm) Diameter (4 Holes) 5/16-24 UNF-2B Thread • Large Capacity Muffler w/Heat Shield and Spark Arrestor • Owner's Manual • Color - Black with Cast Aluminum 					
					
Standard Features Plus:					
• Variable Speed, EPA Emission Compliant	6.5	SH265	SH265-0011		40
Standard Features Plus:					
• Crankshaft - 3/4" Diameter x 2.38" PTO Length, Threaded Pump Shaft, Variable Speed, EPA Emission and RFI Compliant	6.5	SH265	SH265-0013		40
Standard Features Plus:					
• Crankshaft - 5/8" Diameter x 2.44" PTO Length, Threaded Pump Shaft, Variable Speed, EPA Emission and RFI Compliant	6.5	SH265	SH265-0014		40
• Standard Features Like SH265-0014 Plus 50 State Compliant w/evap cap	6.5	SH265	SH265-3014		40
Standard Features Plus:					
• Crankshaft - 0.78" Diameter x 2.82" PTO Length, w/2.25" per foot taper, Fixed Speed (3150 rpm HSNL), EPA Emission and RFI Compliant	6.5	SH265	SH265-0015		40
• Standard Features Like SH265-0015 Plus 50 State Compliant w/evap cap	6.5	SH265	SH265-3015		40
Standard Features Plus:					
• Crankshaft - 0.78" Diameter x 2.82" PTO Length, w/2.25" per foot taper, Fixed Speed (3750 rpm HSNL), EPA Emission Compliant	6.5	SH265	SH265-0016		40
• Standard Features Like SH265-0016 Plus 50 State Compliant w/evap cap and RFI Compliant	6.5	SH265	SH265-3016		40

Note: Contact your source of supply for pricing.

COURAGE SINGLE
15, 16, 18, 20, 21, & 22 HP (Vertical Shaft) Single Cylinder

Description	HP	Model	Spec. No.	List Price	Approx. Ship Wt. (lb.)
Standard Features:					
<ul style="list-style-type: none"> • Overhead Valve Design • Twin Cam Design • Cross-Flow Cylinder Head • Inverted Crankcase • Dual Reciprocating Balance System • Ported Power Intake • Fuel Shutdown Solenoid • Electronic Ignition • Acoustically Dampened Air Induction • Full Pressure Lubrication • Oil Filter • Extended Oil Fill/Dipstick-Yellow • Pulse Fuel Pump • Cast-Iron Cylinder Bore • 15 Amp Regulated/Rectifier Charging • Governed Idle • Unitized Throttle and Choke Control • Variable Speed Governor • Large Capacity In-Line Fuel Filter • Automatic Compression Release • 12V Bendix Electric Starter • Crankshaft -1" (25.4 mm) Diameter x 3.16" (80 mm) PTO Length, 0.25" (6 mm) Keyway, Drilled and Tapped 1.5" (38 mm) Deep, 7/16-20 UNF • PTO Face-10" (254 mm) Diameter, (4 Holes) 0.35" (8.9 mm) x 1" (25.4 mm) Deep 					
	15	SV470S	SV470-0200	\$892.55	81
	16	SV480S	SV480-0200	\$895.62	81
	18	SV540S	SV540-0015*	\$843.61	81
	21	SV610S	SV610-0015*	\$984.11	81
	22	SV620S	SV620-0202	\$1,031.16	81
Standard Features Plus:					
<ul style="list-style-type: none"> • EVAP 					
	15	SV470	SV470-3200	\$892.55	81
	16	SV480	SV480-3200	\$895.63	81
	21	SV610	SV610-3200	\$848.37	81
	22	SV620	SV620-3202	\$1,031.16	81
Standard Features Plus:					
<ul style="list-style-type: none"> • RFI 					
	16	SV480S	SV480-0202	\$937.82	81
	18	SV540S	SV540-0202	\$938.13	81
	20	SV600S	SV600-0202	\$936.57	81
Standard Features Plus:					
<ul style="list-style-type: none"> • RFI • EVAP 					
	16	SV480S	SV480-3202	\$937.82	81
	18	SV540S	SV540-3202	\$938.13	81
	20	SV600	SV600-3202	\$936.57	81

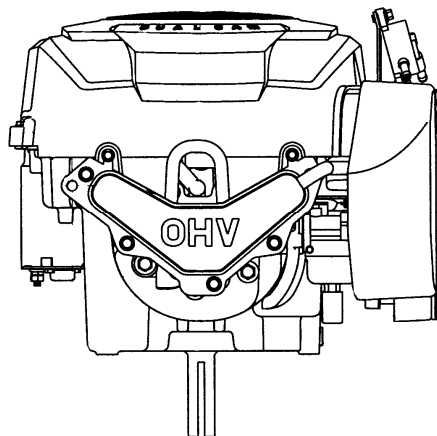

*Limited Quantity Available

COURAGE TWIN
22, 23, 24, 25, & 26 HP (Vertical Shaft) Twin Cylinder

Description	HP	Model	Spec. No.	List Price	Approx. Ship Wt. (lb.)
Standard Features:					
<ul style="list-style-type: none"> • 1.125" Diameter x 4.36" PTO Length, 7/16-20 Unhardened Crankshaft • Cast Iron Cylinder Bore • 10" D.B.C., 4 Cored Holes (For OEM Self-Tap) • Full Pressure Lubrication • 20 Micron Black Oil Filter (73 in² of filtration area) • Automotive Style Dipstick (Yellow) • 7/16" External Square Oil Drain Plug • Stellite Exhaust Valve Seat • 20% Glass-filled Nylon Valve Covers • 12V Bendix Electric Starter • 15A Regulated Charging System • Digital Advance Ignition System (DSAI) - SV735 only • RFI/Ctick Compliance • Black, Glass-filled Nylon Shroud • Modulated Cooling Fan • Fixed Grass Screen Guard • Carburetor w/Fuel Shutdown Solenoid • Pulse Fuel Pump • 51 Micron Fuel Filter (2 in² of filtration area) • Single Wire Controls - Throttle and Choke • Mechanical Governor • Torx Head Boden Screws • Paper Air Cleaner Element • Standard HP Decal (Black with Silver Lettering) • Engine Plate with Emission Certification • Governed Idle Speed 1750 (+150/-250) rpm • High Speed 3300 (+/- 75) rpm • Owner's Manual (English) • Steel Pallet Packing (PS-) • Individual Carton Packing (PH-) • 2 Years Consumer, 90 Days Commercial 					
	22	SV715	SV715-0001	\$1,066.10	106
	23	SV720	SV720-0001	\$1,067.76	106
	24	SV725	SV725-0001	\$1,067.52	106
	25	SV730	SV730-0001	\$1,066.13	106
	26	SV735	SV735-0001	\$1,098.33	106
Standard Features Plus:					
<ul style="list-style-type: none"> • EVAP 					
	22	SV715	SV715-3001	\$1,066.10	106
	23	SV720	SV720-3001	\$1,067.76	106
	24	SV725	SV725-3001	\$1,067.52	106
	24	SV725	SV725-3002	\$1,058.06	106
	25	SV730	SV730-3001	\$1,066.13	106
	26	SV735	SV735-3001	\$1,098.33	106
	26	SV735	SV735-3002	\$1,086.04	106

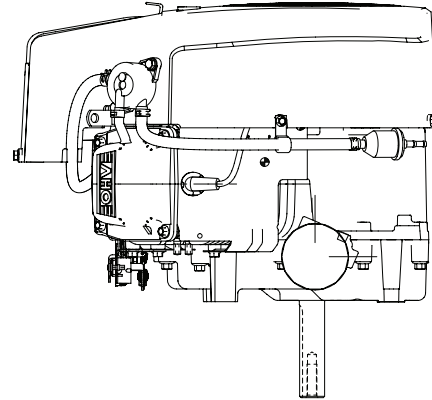

COURAGE PRO TWIN
20, 23, 25, & 27 HP (Vertical Shaft) Twin Cylinder

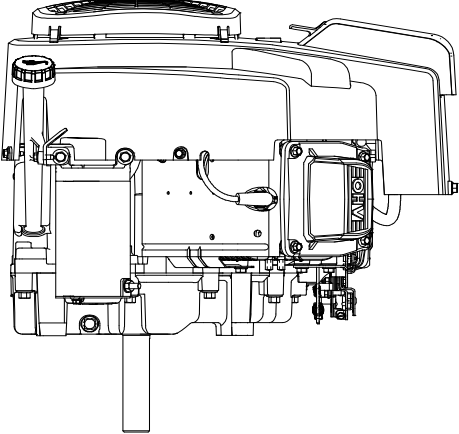
Description	HP	Model	Spec. No.	List Price	Approx. Ship Wt. (lb.)
Standard Features:					
<ul style="list-style-type: none"> • 1.125" Diameter x 4.36" PTO Length, 7/16-20 Unhardened Crankshaft • Cast Iron Cylinder Bore • 10" D.B.C., 4 Cored Holes (For OEM Self-Tap) • Full Pressure Lubrication • 20 Micron Black Oil Filter (73 in² of filtration area) • Automotive Style Dipstick (Yellow) • 7/16" External Square Oil Drain Plug • Stellite Exhaust Valve Seat • 20% Glass-filled Nylon Valve Covers • 12V Bendix Electric Starter • 15A Regulated Charging System • Digital Advance Ignition System (DSAI) – SV840 only • RFI/Ctick Compliance • Black, Glass-filled Nylon Shroud • Modulated Cooling Fan • Fixed Grass Screen Guard • Carburetor w/Fuel Shutdown Solenoid • Pulse Fuel Pump • 51 Micron Fuel Filter (2 in² of filtration area) • Single Wire Controls - Throttle and Choke • Mechanical Governor • Torx Head Boden Screws • Paper Air Cleaner Element • Standard HP Decal (Black with Silver Lettering) • Engine Plate with Emission Certification • Governed Idle Speed 1750 (+150/-250) rpm • High Speed 3300 (+/- 75) rpm • Owner's Manual (English) • Steel Pallet Packing (PS-) • Individual Carton Packing (PH-) • 2 Years Consumer, 1 Year Commercial 					
					
Standard Features Plus:					
• EVAP	20	SV810	SV810-3001	\$1,099.80	106
	23	SV820	SV820-3001	\$1,097.40	106
	25	SV830	SV830-3001	\$1,097.25	106
	27	SV840	SV840-3001	\$1,149.77	106

COMMAND PRO
20-27 HP (Vertical Shaft) V-Twin

Description	HP	Model	Spec. No.	List Price	Approx. Ship Wt. (lb.)
Standard Features:					
<ul style="list-style-type: none"> • Overhead Valve Design • Hydraulic Valve Lifters • Electronic Ignition • Cast-Iron Cylinder Liners • PTO Sleeve Bearing (Side Load) • Digital Spark Advance System (27 HP) • Large Capacity Dual Element Air Cleaner • Closed Breather System • High Efficiency Grass Screen and Fan • Stellite® Exhaust Valves • Full Pressure Lubrication • Large Capacity In-Line Fuel Filter • Easy Access Fill Tube and Dipstick-Yellow • Large Capacity Oil Filter • Dual Oil Drain • Oil Sentry™ (Switch Installed and Wired but Unconnecte • Canister Muffler with Heat Shield, Oil Filter Side Outlet • Variable Speed Governor • High Performance Accelerator Pump Carburetor • Fuel Shutdown Solenoid • Smart-Choke™ Carburetor • Pulse Fuel Pump • High Performance Spark Plugs • 12 Volt Solenoid Shift Starter • 20 Amp Alternator, Regulated • Crankshaft (18-22 HP)-1" (25.4 mm) Diameter x 3.16" (80 mm) PTO Length, 0.25" (6 mm) Keyway, Drilled and Tapped 1.5" (38 mm) Deep, 7/16-20 UNF • Crankshaft (25-27 HP)-1.125" (28.5 mm) Diameter x 3.16" (80 mm) PTO Length, 0.25" (6 mm) Keyway, Drilled and Tapped 1.5" (38 mm) Deep, 7/16-20 UNF 					
	20	CV20S	65549	\$1,650.43	108
	25	CV730S	CV730-0001	\$1,940.78	108
	27	CV740S	CV740-0001	\$2,094.88	100
Standard Features Plus:					
• 3/16" Evaporative emissions connection	20	CV640	CV640-3002	\$1,650.43	108
	25	CV730	CV730-3101	\$1,940.78	108
	27	CV740	CV740-3001	\$2,094.88	100
Standard Features Plus:					
• Universal Commercial Mowing Replacement Engine					
• Special Chopper Grass Screen and Fixed Guard					
• No Exhaust System-Studs, Nuts, and Gaskets only	23	CV23S	75550	\$1,711.97	106
• Standard Features Like 75550 Plus 3/16" Evaporative emissions connection	23	CV680	CV680-3002	\$1,711.97	106

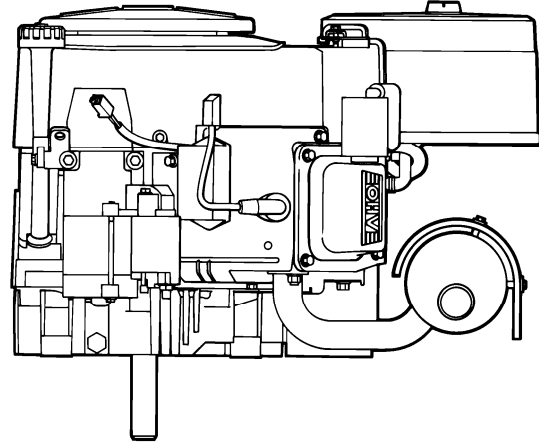

COMMAND PRO 30 HP (Vertical Shaft) V-Twin

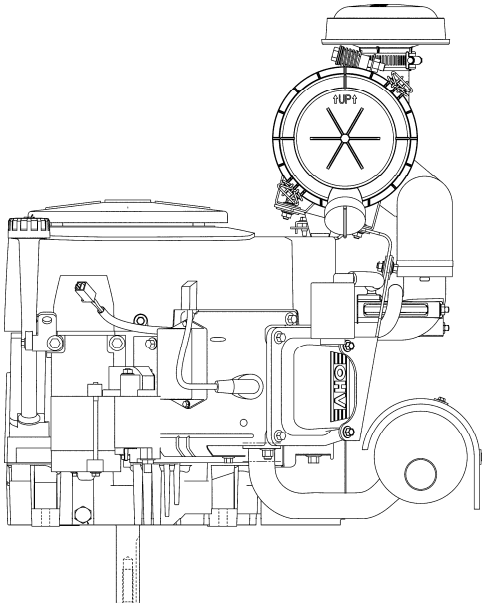
Description	HP	Model	Spec. No.	List Price	Approx. Ship Wt. (lb.)
Standard Features:					
<ul style="list-style-type: none"> • Overhead Valve Design • Hydraulic Valve Lifters • Electronic Ignition • Cast-Iron Cylinder Liners • PTO Sleeve Bearing (Side Load) • Digital Spark Advance System • Heavy Duty Canister Air Cleaner System • Closed Breather System • High Efficiency Grass Screen and Fan • Stellite® Exhaust Valves • Full Pressure Lubrication • Large Capacity In-Line Fuel Filter • Easy Access Fill Tube and Dipstick-Yellow • Large Capacity Oil Filter • Dual Oil Drain • Oil Sentry™ (Switch Installed and Wired but Unconnected) • Canister Muffler with Heat Shield, Oil Filter Side Outlet • Variable Speed Governor • Two-Barrel Carburetor • Fuel Shutdown Solenoid • Smart-Choke™ Carburetor • Pulse Fuel Pump • High Performance Spark Plugs • 12 Volt Solenoid Shift Starter • 20 Amp Alternator, Regulated • Crankshaft - 1.125" (28.5 mm) Diameter x 3.16" (80 mm) PTO Length, 0.25" (6 mm) Keyway, Drilled and Tapped 1.5" (38 mm) Deep, 7/16-20 UNF • PTO Face - 10" (254 mm) Diameter, 4 Through Holes, 0.36" (9 mm) Diameter Color-Black with Cast Aluminum 					
					
Standard Features Plus:					
<ul style="list-style-type: none"> • Special Chopper Grass Screen and Fixed Guard 					
	30	CV750S	CV750-0005	\$2,341.90	110
	30	CV750	CV750-3005	\$2,341.90	110

COMMAND PRO
34, 36, 38, & 40 HP (Vertical Shaft) V-Twin

Description	HP	Model	Spec. No.	List Price	Approx. Ship Wt. (lb.)
-------------	----	-------	--------------	---------------	---------------------------

Standard Features:

- Overhead Valve Design
- Hydraulic Valve Lifters
- Nylon Cam Gear
- Cast-Iron Cylinder Liners
- Stellite® Exhaust Valves
- Flywheel and PTO Sleeve Bearings
- Electronic Ignition
- High Performance Spark Plugs RFI and EMC Compliant
- Full Pressure Lubrication
- Top Mount Spin-On Large Capacity Oil Filter
- Large Dual Oil Drains
- Heavy Duty Canister Air Cleaner System
- High Efficiency Grass Screen and Fan
- Fixed Grass Screen Guard
- Blower Housing with Removable Cylinder Access Covers
- Easy Access Dipstick and Oil Fill-Yellow
- Oil Sentry™ (Switch Installed but Unconnected)
- Variable Speed Governor
- Top Mounted Remote Controls (for boden wire connection)
- Closed Breather System
- Two-Barrel Carburetor
- Fuel Shutdown Solenoid
- Smart-Choke™ Carburetor
- Pulse Fuel Pump
- Large Capacity In-Line Fuel Filter
- 12 Volt Solenoid Shift Starter
- 20 Amp Alternator, Regulated
- Crankshaft-1.125" (28.5 mm) Diameter x 3.16" (80 mm) PTO Length,
0.25" (6 mm) Keyway, Drilled and Tapped 1.5" (38 mm) Deep, 7/16-20 UNF
- PTO Face-10" (254 mm) Diameter, (4 Holes) M8 x 1.25
- Canister Muffler with Heat Shield, Opposite Starter Side Outlet
- Color-Black with Cast Aluminum

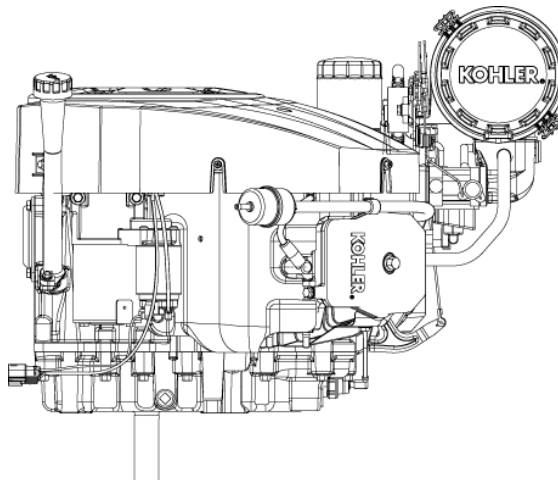

34	CV940S	CV940-0002	\$2,184.14	127
36	CV960S	CV960-0002	\$2,337.16	127
38	CV980S	CV980-0002	\$2,566.67	127
40	CV1000S	CV1000-0002	\$2,864.20	127

Standard Features Plus

- 3/16" Evaporative emissions connection

34	CV940	CV940-2002	\$2,184.14	127
36	CV960	CV960-2002	\$2,337.16	127
38	CV980	CV980-2002	\$2,566.67	127

Exhaust System Kits

Kit/Part No.	Description	List Price
62 786 04-S	PTO Canister Muffler Kit-Center Outlet (Includes Muffler).....	\$129.76
62 786 05-S	PTO Canister Muffler Kit-Starter Side Outlet (Includes Muffler).....	\$129.76
62 786 06-S	PTO Canister Muffler Kit-Opposite Starter Side Outlet (Includes Muffler).....	\$129.76

COMMAND PRO SMALL HORIZONTAL 7 HP (Horizontal Shaft) Single Cylinder

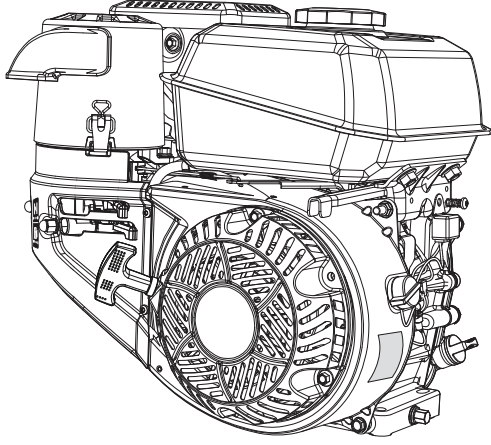
Description	HP	Model	Spec. No.	List Price	Approx. Ship Wt. (lb.)
Standard Features:					
<ul style="list-style-type: none"> • Overhead Valve Design • Electronic Ignition • Quad-Clean™ 4-Stage All-Season Heavy Duty Cyclonic Air Cleaner • Dual Oil Fill Locations and Oil Drains • Cast Iron Cylinder Liner • 4.1 L Metal Tank w/Strainer • Fuel Shut-off Valve • Stellite® Exhaust Valve • Engine Mounted Throttle and Choke Controls, Remote Throttle Ready • Oil Sentry™ Switch Installed (No Light) • Dual Ball Bearings, PTO and Flywheel • Metal Blower Housing • Indexable Recoil Starter • Crankshaft - 0.75" (19.05 mm) Diameter x 2.42" (61.47 mm) PTO Length, Tapped 5/16-24 UNF • PTO Face - 3.625" (92.08 mm) Diameter (4 Holes) 5/16-24 UNF 2B Thread • Large Capacity Muffler w/Heat Shield and Spark Arrestor • Owner's Manual (Multi-language for Europe or Quad-language for rest of the world) • EPA Phase 2, EU Stage 2 Emission Compliance • Color - Black with Cast Aluminum 					
					
Standard Features Plus:					
<ul style="list-style-type: none"> • Crankshaft - 3/4" Diameter x 2.42" PTO Length, Straight Shaft w/Keyway, Variable Speed, RFI Compliant, Quad-language manual (English, Spanish, French, Chinese) 	7	CH270	CH270-0011		40
Standard Features Plus:					
<ul style="list-style-type: none"> • Crankshaft - 3/4" Diameter x 2.41" PTO Length, Straight Shaft w/Threads, Variable Speed, RFI Compliant, Quad-language manual (English, Spanish, French, Chinese) 	7	CH270	CH270-0013		40
Standard Features Plus:					
<ul style="list-style-type: none"> • Crankshaft - 5/8" Diameter x 2.44" PTO Length, Threaded Pump Shaft, Variable Speed, RFI Compliant, Quad-language manual (English, Spanish, French, Chinese) 	7	CH270	CH270-0014		40
Standard Features Plus:					
<ul style="list-style-type: none"> • Crankshaft - 0.78" Diameter x 2.82" PTO Length, w/2.25" per foot Taper Shaft, Fixed Speed (3150 rpm HSNL), RFI Compliant, Multi-language manual (English, Spanish, French, Italian, German, Russian) 	7	CH270	CH270-0015		40
Standard Features Plus:					
<ul style="list-style-type: none"> • Crankshaft - 0.78" Diameter x 2.82" PTO Length, w/2.25" per foot Taper Shaft, Fixed Speed (3750 rpm HSNL), Quad-language manual (English, Spanish, French, Chinese) 	7	CH270	CH270-0016		40
Note: Contact your source of supply for pricing.					

**COMMAND PRO SMALL HORIZONTAL
7 HP (Horizontal Shaft) Single Cylinder**

Description	HP	Model	Spec. No.	List Price	Approx. Ship Wt. (lb.)
Standard Features Plus:					
• Crankshaft - 3/4" Diameter x 2.42" PTO Length, Straight Shaft w/Keyway, Variable Speed, 50 State Compliant w/evap cap, Quad-language manual (English, Spanish, French, Chinese)	7	CH270	CH270-3011		40
Standard Features Plus:					
• Crankshaft - 5/8" Diameter x 2.44" PTO Length, Threaded Pump Shaft, Variable Speed, 50 State Compliant w/evap cap, Quad-language manual (English, Spanish, French, Chinese)	7	CH270	CH270-3014		40
Standard Features Plus:					
• Crankshaft - 0.78" Diameter x 2.82" PTO Length, w/2.25" per foot Taper Shaft, Fixed Speed (3750 rpm HSNL), 50 State Compliant w/evap cap, Quad-language manual (English, Spanish, French, Chinese)	7	CH270	CH270-3016		40

Note: Contact your source of supply for pricing.

COMMAND PRO SMALL HORIZONTAL 9.5 HP (Horizontal Shaft) Single Cylinder

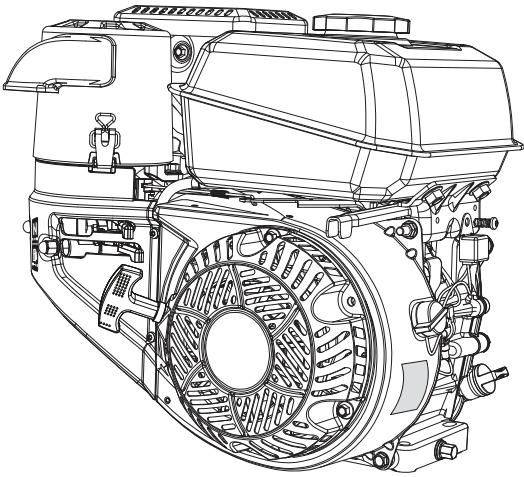
Description	HP	Model	Spec. No.	List Price	Approx. Ship Wt. (lb.)
Standard Features:					
<ul style="list-style-type: none"> • Overhead Valve Design • Electronic Ignition • Quad-Clean™ 4-Stage All-Season Heavy Duty Cyclonic Air Cleaner • Dual Oil Fill Locations and Oil Drains • Cast Iron Cylinder Liner • 7.4 L Metal Tank w/Strainer • Fuel Shut-off Valve • Stellite® Exhaust Valve • Engine Mounted Throttle and Choke Controls, Remote Throttle Ready • Oil Sentry™ Switch Installed (No Light) • Dual Ball Bearings, PTO and Flywheel • Balance Shaft • Metal Blower Housing • Indexable Recoil Starter • Crankshaft - 1.0" (25.4 mm) Diameter x 3.49" (88.61 mm) PTO Length, Tapped 7/16-20 UNF • PTO Face - 6.5" (165.1 mm) Diameter Bolt Circle (4 Holes) 3/8-16 UNC x 0.71" (18 mm) Deep and 5" (127 mm) Diameter Bolt Circle (4 Holes) 5/16-24 UNF x 0.71" (18 mm) Deep • Large Capacity Muffler w/Heat Shield and Spark Arrestor • Owner's Manual (Multi-language for Europe or Quad-language for rest of the world) • EPA Phase 2 and EU Stage 2 Emission Compliance • Color - Black with Cast Aluminum 					
					
Standard Features Plus:					
<ul style="list-style-type: none"> • Variable Speed, RFI Compliant, Quad-language manual (English, Spanish, French, Chinese) 	9.5	CH395	CH395-0011		62
<ul style="list-style-type: none"> • Standard Features Like CH395-0011 Plus 50 State Compliant w/evap cap 	9.5	CH395	CH395-3011		62
Standard Features Plus:					
<ul style="list-style-type: none"> • Crankshaft - 1" Diameter x 3.51" PTO Length, Threaded Pump Shaft, Variable Speed, RFI Compliant, Quad-language manual (English, Spanish, French, Chinese) 	9.5	CH395	CH395-0014		62
Standard Features Plus:					
<ul style="list-style-type: none"> • Crankshaft - 0.87" Diameter x 4.18" PTO Length, w/2.25" per foot Taper Shaft, Fixed Speed (3150 rpm HSNL), RFI Compliant, Multi-language manual (English, Spanish, French, Italian, German, Russian) 	9.5	CH395	CH395-0015		62
Standard Features Plus:					
<ul style="list-style-type: none"> • Crankshaft - 0.87" Diameter x 4.18" PTO Length, w/2.25" per foot Taper Shaft, Fixed Speed (3750 rpm HSNL), Quad-language manual (English, Spanish, French, Chinese) 	9.5	CH395	CH395-0016		62
<ul style="list-style-type: none"> • Standard Features Like CH395-0016 Plus 50 State Compliant w/evap cap, RFI Compliant 	9.5	CH395	CH395-3016		62

**COMMAND PRO SMALL HORIZONTAL
9.5 HP (Horizontal Shaft) Single Cylinder**

Description	HP	Model	Spec. No.	List Price	Approx. Ship Wt. (lb.)
Standard Features Plus:					
<ul style="list-style-type: none"> • Variable Speed, RFI Compliant, 12 V electric starter, 3 amp charging system, Quad-language manual (English, Spanish, French, Chinese) 	9.5	CH395	CH395-0021		62
Standard Features Plus:					
<ul style="list-style-type: none"> • Crankshaft - 1" Diameter x 3.51" PTO Length, Threaded Pump Shaft, Variable Speed, RFI Compliant, 12 V electric starter, 3 amp charging system Quad-language manual (English, Spanish, French, Chinese) 	9.5	CH395	CH395-0024		62
Standard Features Plus:					
<ul style="list-style-type: none"> • Crankshaft - 0.87" Diameter x 4.18" PTO Length, w/2.25" per foot Taper Shaft, Fixed Speed (3150 rpm HSNL), RFI Compliant, 12 V electric starter, 3 amp charging system, Multi-language manual (English, Spanish, French, Italian, German, Russian) 	9.5	CH395	CH395-0025		62
Standard Features Plus:					
<ul style="list-style-type: none"> • Crankshaft - 0.87" Diameter x 4.18" PTO Length, w/2.25" per foot Taper Shaft, Fixed Speed (3750 rpm HSNL), 12 V electric starter, 3 amp charging system, Quad-language manual (English, Spanish, French, Chinese) 	9.5	CH395	CH395-0026		62
<ul style="list-style-type: none"> • Standard Features Like CH395-0026 Plus 50 State Compliant w/evap cap 	9.5	CH395	CH395-3026		62
Standard Features Plus:					
<ul style="list-style-type: none"> • Variable Speed, RFI Compliant, 12 V electric starter, 3 amp charging system, 50 State Compliant w/evap cap, Multi-language manual (English, Spanish, French, Italian, German, Russian) 	9.5	CH395	CH395-3021		62
Standard Features Plus:					
<ul style="list-style-type: none"> • Variable Speed, RFI Compliant, 12 V electric starter, 10 amp charging system, Quad-language manual (English, Spanish, French, Chinese) 	9.5	CH395	CH395-0031		62

Note: Contact your source of supply for pricing.

**COMMAND PRO SMALL HORIZONTAL
9.5 HP (Horizontal Shaft) Single Cylinder**

Description	HP	Model	Spec. No.	List Price	Approx. Ship Wt. (lb.)
Standard Features Plus:					
<ul style="list-style-type: none"> Variable Speed, RFI Compliant, 12 V electric starter, 10 amp charging system, 50 State Compliant w/evap cap, Multi-language manual (English, Spanish, French, Italian, German, Russian) 	9.5	CH395	CH395-3031		62
Standard Features Plus:					
<ul style="list-style-type: none"> Variable Speed, RFI Compliant, 12 V electric starter, 18 amp charging system, Quad-language manual (English, Spanish, French, Chinese) 	9.5	CH395	CH395-0041		62
Standard Features Plus:					
<ul style="list-style-type: none"> Variable Speed, RFI Compliant, 12 V electric starter, 18 amp charging system, 50 State Compliant w/evap cap, Multi-language manual (English, Spanish, French, Italian, German, Russian) 	9.5	CH395	CH395-3041		62

Note: Contact your source of supply for pricing.

COMMAND PRO SMALL HORIZONTAL 14 HP (Horizontal Shaft) Single Cylinder

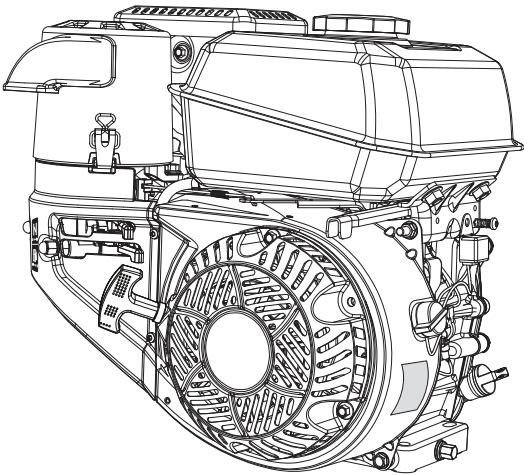
Description	HP	Model	Spec. No.	List Price	Approx. Ship Wt. (lb.)
Standard Features:					
<ul style="list-style-type: none"> • Overhead Valve Design • Electronic Ignition • Quad-Clean™ 4-Stage All-Season Heavy Duty Cyclonic Air Cleaner • Dual Oil Fill Locations and Oil Drains • Cast Iron Cylinder Liner • 7.4 L Metal Tank w/Strainer • Fuel Shut-off Valve • Stellite® Exhaust Valve • Engine Mounted Throttle and Choke Controls, Remote Throttle Ready • Oil Sentry™ Switch Installed (No Light) • Dual Ball Bearings, PTO and Flywheel • Balance Shaft • Metal Blower Housing • Indexable Recoil Starter • Crankshaft - 1.0" (25.4 mm) Diameter x 3.49" (88.61 mm) PTO Length, Tapped 3/8-24 UNF • PTO Face - 6.5" (165.1 mm) Diameter Bolt Circle (4 Holes) 3/8-16 UNC x 0.71" (18 mm) Deep and 5" (127 mm) Diameter Bolt Circle (4 Holes) 5/16-24 UNF x 0.71" (18 mm) Deep • Large Capacity Muffler w/Heat Shield and Spark Arrestor • Owner's Manual (Multi-language for Europe or Quad-language for rest of the world) • EPA Phase 2 and EU Stage 2 Emission Compliance • Color - Black with Cast Aluminum 					
					
Standard Features Plus:					
<ul style="list-style-type: none"> • Variable Speed, RFI Compliant, Multi-language manual (English, Spanish, French, Italian, German, Russian) 	14	CH440	CH440-0011		73
<ul style="list-style-type: none"> • Standard Features Like CH440-0011 Plus 50 State Compliant w/evap cap 	14	CH440	CH440-3011		73
Standard Features Plus:					
<ul style="list-style-type: none"> • Crankshaft - 1" Diameter x 3.51" PTO Length, Threaded Pump Shaft, Variable Speed, RFI Compliant, Multi-language manual (English, Spanish, French, Italian, German, Russian) 	14	CH440	CH440-0014		73
<ul style="list-style-type: none"> • Standard Features Like CH440-0014 Plus 50 State Compliant w/evap cap 	14	CH440	CH440-3014		73
Standard Features Plus:					
<ul style="list-style-type: none"> • Crankshaft - 0.87" Diameter x 4.18" PTO Length, w/2.25" per foot Taper Shaft, Fixed Speed (3150 rpm HSNL), RFI Compliant, Multi-language manual (English, Spanish, French, Italian, German, Russian) 	14	CH440	CH440-0015		73

Note: Contact your source of supply for pricing.

**COMMAND PRO SMALL HORIZONTAL
14 HP (Horizontal Shaft) Single Cylinder**

Description	HP	Model	Spec. No.	List Price	Approx. Ship Wt. (lb.)
Standard Features Plus:					
• Crankshaft - 0.87" Diameter x 4.18" PTO Length, w/2.25" per foot Taper Shaft, Fixed Speed (3750 rpm HSNL), Multi-language manual (English, Spanish, French, Italian, German, Russian)	14	CH440	CH440-0016		73
• Standard Features Like CH440-0016 Plus 50 State Compliant w/evap cap	14	CH440	CH440-3016		73
Standard Features Plus:					
• Variable Speed, RFI Compliant, 12 V electric starter, 3 amp charging system, Multi-language manual (English, Spanish, French, Italian, German, Russian)	14	CH440	CH440-0021		73
• Standard Features Like CH440-0021 Plus 50 State Compliant w/evap cap	14	CH440	CH440-3021		73
Standard Features Plus:					
• Crankshaft - 1" Diameter x 3.51" PTO Length, Threaded Pump Shaft, Variable Speed, RFI Compliant, 12 V electric starter, 3 amp charging system, Multi-language manual (English, Spanish, French, Italian, German, Russian)	14	CH440	CH440-0024		73
• Standard Features Like CH440-0024 Plus 50 State Compliant w/evap cap	14	CH440	CH440-3024		73
Standard Features Plus:					
• Crankshaft - 0.87" Diameter x 4.18" PTO Length, w/2.25" per foot Taper Shaft, Fixed Speed (3150 rpm HSNL), RFI Compliant, 12 V electric starter, 3 amp charging system, Multi-language manual (English, Spanish, French, Italian, German, Russian)	14	CH440	CH440-0025		73
Standard Features Plus:					
• Crankshaft - 0.87" Diameter x 4.18" PTO Length, w/2.25" per foot Taper Shaft, Fixed Speed (3750 rpm HSNL), 12 V electric starter, 3 amp charging system, Multi-language manual (English, Spanish, French, Italian, German, Russian)	14	CH440	CH440-0026		73
• Standard Features Like CH440-0026 Plus 50 State Compliant w/evap cap	14	CH440	CH440-3026		73
Standard Features Plus:					
• Variable Speed, RFI Compliant, 12 V electric starter, 10 amp charging system, Multi-language manual (English, Spanish, French, Italian, German, Russian)	14	CH440	CH440-0031		73
• Standard Features Like CH440-0031 Plus 50 State Compliant w/evap cap	14	CH440	CH440-3031		73

Note: Contact your source of supply for pricing.

**COMMAND PRO SMALL HORIZONTAL
14 HP (Horizontal Shaft) Single Cylinder**

Description	HP	Model	Spec. No.	List Price	Approx. Ship Wt. (lb.)
Standard Features Plus:					
<ul style="list-style-type: none"> • Crankshaft - 1" Diameter x 3.51" PTO Length, Threaded Pump Shaft, Variable Speed, RFI Compliant, 12 V electric starter, 10 amp charging system, Multi-language manual (English, Spanish, French, Italian, German, Russian) 	14	CH440	CH440-0034		73
<ul style="list-style-type: none"> • Standard Features Like CH440-0034 Plus 50 State Compliant w/evap cap 	14	CH440	CH440-3034		73
Standard Features Plus:					
<ul style="list-style-type: none"> • Crankshaft - 0.87" Diameter x 4.18" PTO Length, w/2.25" per foot Taper Shaft, Fixed Speed (3150 rpm HSNL), RFI Compliant, 12 V electric starter, 10 amp charging system, Multi-language manual (English, Spanish, French, Italian, German, Russian) 	14	CH440	CH440-0035		73
Standard Features Plus:					
<ul style="list-style-type: none"> • Crankshaft - 0.87" Diameter x 4.18" PTO Length, w/2.25" per foot Taper Shaft, Fixed Speed (3750 rpm HSNL), 12 V electric starter, 10 amp charging system, Multi-language manual (English, Spanish, French, Italian, German, Russian) 	14	CH440	CH440-0036		73
<ul style="list-style-type: none"> • Standard Features Like CH440-0036 Plus 50 State Compliant w/evap cap 	14	CH440	CH440-3036		73
Standard Features Plus:					
<ul style="list-style-type: none"> • Variable Speed, RFI Compliant, 12 V electric starter, 18 amp charging system, Multi-language manual (English, Spanish, French, Italian, German, Russian) 	14	CH440	CH440-0041		73
<ul style="list-style-type: none"> • Standard Features Like CH440-0041 Plus 50 State Compliant w/evap cap 	14	CH440	CH440-3041		73

Note: Contact your source of supply for pricing.

COMMAND PRO
18-27 HP (Horizontal Shaft) V-Twin

Description	HP	Model	Spec. No.	List Price	Approx. Ship Wt. (lb.)
Standard Features:					
<ul style="list-style-type: none"> • Overhead Valve Design • Hydraulic Valve Lifters • Digital Spark Advance System (27 HP) • Cast-Iron Cylinder Liners • PTO Sleeve Bearing (Side Load) (25 & 27 HP) • Electronic Ignition • Large Capacity Dual Element Air Cleaner • High Efficiency Grass Screen and Fan • Closed Breather System • Stellite® Exhaust Valves • Full Pressure Lubrication • Large Capacity In-Line Fuel Filter • Easy Access Valve Cover Oil Fill-Yellow • Oil Level Dipstick-Yellow • Large Capacity Oil Filter, Dual Oil Drain • Oil Sentry™ (Switch Installed and Wired but Unconnected) • Variable Speed Governor • High Performance Accelerator Pump Carburetor (25 & 27 HP) • Fuel Shutdown Solenoid, Smart-Choke™ Carburetor • Mechanical Fuel Pump • High Performance Spark Plugs • 12 Volt Solenoid Shift Starter • 20 Amp Alternator, Regulated • Crankshaft-1.437" (36 mm) Diameter x 4.453" (113 mm) PTO Length, 0.375" (9.5 mm) Keyway, Drilled and Tapped 1.5" (38 mm) Deep, 5/8-18 UNF • PTO Face-5.625" (143 mm) Diameter, (4 Holes) 3/8-16 x 0.67" (17 mm) Deep, 7.75" (197 mm) Diameter, (4 Holes) 7/16-14 x 0.83" (21 mm) Deep • 7" (178 mm) Diameter Pilot • Color-Black with Cast Aluminum • See page 38 for Exhaust System Kits 					
Standard Features Plus:					
• Blower Housing to Accept Fixed Guard	25	CH730S	CH730-0038	\$1,606.44	108
	25	CH730S	CH730-3038*	\$1,640.44	108
	27	CH740S	CH740-0012	\$2,012.46	108
	27	CH740S	CH740-3012*	\$2,044.88	108
Standard Features Plus:					
• Blower Housing to Accept Fixed Guard	25	CH730	CH730-3208	\$1,606.44	108
• 3/16" Evaporative emissions connection	27	CH740	CH740-3006	\$2,012.46	108
	27	CH740	CH740-3009	\$2,043.90	108
Standard Features Plus:					
• Engine Controls-Key Switch, Throttle and Choke Controls	20	CH20S	64594	\$1,635.09	106
	23	CH23S	76501	\$1,679.30	106
• Fixed Grass Screen Guard (25 & 27 HP)	25	CH730S	CH730-0040	\$1,879.81	108
	25	CH730S	CH730-3040*	\$1,913.81	108
	27	CH740S	CH740-0013	\$2,071.93	108
Standard Features Plus:					
• Engine Controls-Key Switch, Throttle and Choke Controls	20	CH640	CH640-3007	\$1,635.09	106
	23	CH680	CH680-3002	\$1,679.30	106
• Fixed Grass Screen Guard (25 & 27 HP)	25	CH730	CH730-3203	\$1,879.81	108
• 3/16" Evaporative emissions connection	27	CH740	CH740-3005	\$2,071.93	108

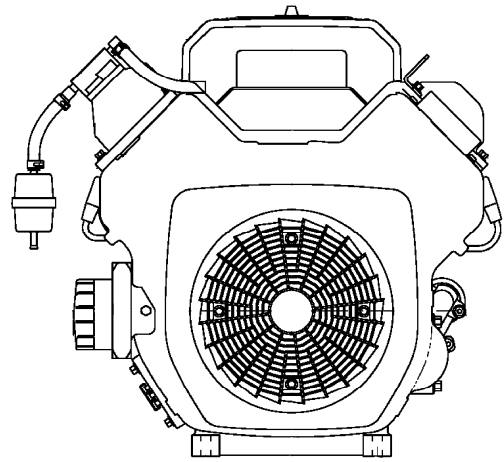

*50-State Emission Version

COMMAND PRO
18-27 HP (Horizontal Shaft) V-Twin

Description	HP	Model	Spec. No.	List Price	Approx. Ship Wt. (lb.)
Standard Features Plus:					
• Crankshaft-1.125" (28.5 mm) Diameter x 4.0" (102 mm) PTO Length, 0.25" (6 mm) Keyway, Drilled and Tapped 1.5"(38 mm) Deep, 7/16-20 UNF	18	CH18S	62587	\$1,433.32	106
	20	CH20S	64595	\$1,635.09	106
• Engine Controls-Key Switch, Throttle and Choke Controls	23	CH23S	76601	\$1,638.46	106
	25	CH730S	CH730-0039	\$1,879.81	108
• Fixed Grass Screen Guard (25 HP)	25	CH730S	CH730-3039*	\$1,913.88	108
Standard Features Plus:					
• Crankshaft-1.125" (28.5 mm) Diameter x 4.0" (102 mm) PTO Length, 0.25" (6 mm) Keyway, Drilled and Tapped 1.5"(38 mm) Deep, 7/16-20 UNF	18	CH620	CH620-3053	\$1,433.32	106
• Engine Controls-Key Switch, Throttle and Choke Controls	20	CH640	CH640-3008	\$1,635.09	106
	23	CH680	CH680-3001	\$1,638.46	106
• Fixed Grass Screen Guard (25 HP)	25	CH730	CH730-3201	\$1,879.81	108
• 3/16" Evaporative emissions connection	25	CH730	CH730-3209	\$1,913.88	108
Standard Features Plus:					
• Crankshaft-1.125" (28.5 mm) Diameter x 4.0" (102 mm) PTO Length, 0.25" (6 mm) Keyway, Drilled and Tapped 1.5" (38 mm) Deep, 7/16-20 UNF					
• Engine Controls-Key Switch, Throttle and Choke Controls					
• Anti-Icing Features with Starter Side Exhaust System					
• Round Air Cleaner with Snorkel to Starter Side Muffler	20	CH20S	64672	\$1,725.25	106
	25	CH730S	CH730-0041	\$1,988.17	109
• Fixed Grass Screen Guard	27	CH740S	CH740-0004	\$2,272.69	106
Standard Features Plus:					
• Crankshaft-1.125" (28.5 mm) Diameter x 4.0" (102 mm) PTO Length, 0.25" (6 mm) Keyway, Drilled and Tapped 1.5" (38 mm) Deep, 7/16-20 UNF					
• Engine Controls-Key Switch, Throttle and Choke Controls					
• Anti-Icing Features with Starter Side Exhaust System					
• Round Air Cleaner with Snorkel to Starter Side Muffler					
• Fixed Grass Screen Guard	20	CH640	CH640-3005	\$1,725.25	106
	25	CH730	CH730-3202	\$1,988.17	109
• 3/16" Evaporative emissions connection	27	CH740	CH740-3004	\$2,272.69	106

*50-State Emission Version

COMMAND PRO
18-27 HP (Horizontal Shaft) V-Twin

Description	HP	Model	Spec. No.	List Price	Approx. Ship Wt. (lb.)
Standard Features Plus:					
<ul style="list-style-type: none"> • Crankshaft-1.125" (28.5 mm) Diameter x 4.0" (102 mm) PTO Length, 0.25" (6 mm) Keyway, Drilled and Tapped 1.5" (38 mm) Deep, 7/16-20 UNF • Engine Controls-Key Switch, Throttle and Choke Controls • Anti-Icing Features with Starter Side Exhaust System • Round Air Cleaner with Snorkel to Starter Side Muffler • Fixed Grass Screen Guard • PTO Thrust Bearing 	27	CH740S	CH740-0071	\$2,272.69	106
Standard Features Plus:					
<ul style="list-style-type: none"> • Crankshaft-2.25" (57.15 mm) Per Foot (305 mm) Taper, 1.5" (38 mm) Diameter x 3.94" (100.1 mm) PTO Length, Drilled and Tapped 0.625" (16 mm) Deep, 5/16-24 UNF • No PTO Thrust Bearing • PTO Face-5.625" (143 mm) Diameter, (4 Holes) 3/8-16 x 0.67" (17 mm) Deep, 7.75" Diameter, (4 Holes) 7/16-14 x 0.83" (21 mm) Deep • 6.437" (163 mm) Diameter Pilot • Oil Sentry™ Wired for Shutdown • Fixed Grass Screen Guard • Engine Controls-Key Switch and Choke Control • 5% Governor Regulation • Constant Speed @ 3200 RPM • Standard Features of CH730-0108 Plus 3/16" Evaporative emissions connection 	25	CH730GS	CH730-0108	\$1,958.54	108
<ul style="list-style-type: none"> • Standard Features of CH730-0108 Plus 3/16" Evaporative emissions connection 	25	CH730	CH730-3210	\$1,958.54	108
Standard Features Plus:					
<ul style="list-style-type: none"> • Engine Mounted Throttle and Choke Controls • Key Switch Shipped as an Accessory • Fixed Grass Screen Guard • 25 Amp Alternator, Regulated • Crankshaft-1.5" (38 mm) Diameter x 0.452" (11.5 mm) PTO Length, 13 Tooth Spline, SAE "B" Mount Hydraulic Pump Adaptor • Standard Features of CH730-3131 Plus 3/16" Evaporative emissions connection 	25	CH730S	CH730-0131	\$1,933.73	110
	25	CH730S	CH730-3131*	\$1,966.24	110
<ul style="list-style-type: none"> • Standard Features of CH730-3131 Plus 3/16" Evaporative emissions connection 	25	CH730	CH730-3206	\$1,966.24	110

* 50-State Emission Version

**COMMAND PRO
18-27 HP (Horizontal Shaft) V-Twin**

Description	HP	Model	Spec. No.	List Price	Approx. Ship Wt. (lb.)
Standard Features Plus:					
Super Spec					
<ul style="list-style-type: none"> • 25 Amp Alternator • Dual Oil Fill • Clean Out Covers - Right Side Cover has Provision for Key Switch to be Added • 50 State Compliant • Provision for Adding Fixed Grass Screen Guard • To Add Controls Use These Parts: 24 225 02-S Throttle & Choke Assembly, 25 099 04-S Key Switch, Decals 24 113 126-S & 24 113 91-S 					
	25	CH730S	CH730-3217*	\$1,820.25	108
• Standard Features of CH730-3217 Plus 3/16" Evaporative emissions connection	25	CH730	CH730-3207	\$1,820.25	108

* 50-State Emission Version

COMMAND PRO
25, 27, & 28 HP (Horizontal Shaft) V-Twin

Description	HP	Model	Spec. No.	List Price	Approx. Ship Wt. (lb.)
Standard Features:					
<ul style="list-style-type: none"> • Overhead Valve Design • Hydraulic Valve Lifters • Heavy Duty Canister Air Cleaner System • Fixed Grass Screen Guard • Digital Spark Advance System (27 HP) • Cast-Iron Cylinder Liners • PTO Sleeve Bearing (Side Load) • Electronic Ignition • High Efficiency Grass Screen and Fan • Closed Breather System • Stellite® Exhaust Valves • Full Pressure Lubrication • Large Capacity In-Line Fuel Filter • Easy Access Valve Cover Oil Fill-Yellow • Oil Level Dipstick-Yellow • Large Capacity Oil Filter • Dual Oil Drain • Oil Sentry™ (Switch Installed and Wired but Unconnected) • Variable Speed Governor • High Performance Accelerator Pump Carburetor • Fuel Shutdown Solenoid • Smart-Choke™ Carburetor • Mechanical Fuel Pump • High Performance Spark Plugs • 12 Volt Solenoid Shift Starter • 20 Amp Alternator, Regulated • Crankshaft-1.437" (36 mm) Diameter x 4.46" (113 mm) PTO Length, 0.375" (9.5 mm) Keyway, Drilled and Tapped 1.5" (38 mm) Deep, 5/8-18 UNF • PTO Face-5.625" (143 mm) Diameter, (4 Holes) 3/8-16 x 0.67" (17 mm) Deep, 7.75" (197 mm) Diameter, (4 Holes) 7/16-14 x 0.83" (21 mm) Deep • 7" (178 mm) Diameter Pilot • Color-Black with Cast Aluminum • See page 38 for Exhaust System Kits • Standard Features Like CH740-0060 Plus EVAP 					
	27	CH740S	CH740-0060	\$2,061.28	108
	27	CH740	CH740-3007	\$2,061.28	108
Standard Features Plus:					
• Engine Controls-Key Switch, Throttle and Choke Controls	25	CH730S	CH730-0001	\$1,936.11	108
	27	CH740S	CH740-0001	\$2,128.42	108
	27	CH740S	CH740-3001*	\$2,162.42	108
Standard Features Plus:					
• Engine Controls-Key Switch, Throttle and Choke Controls	25	CH730	CH730-3200	\$1,936.11	108
	27	CH740	CH740-3002	\$2,128.42	108
• 3/16" Evaporative emissions connection	27	CH740	CH740-3101	\$2,162.42	108
Standard Features Plus:					
• Crankshaft-1.125" (28.5 mm) Diameter x 4.0" (102 mm) PTO Length, 0.25" (6 mm) Keyway, Drilled and Tapped 1.5" (38 mm) Deep, 7/16-20 UNF					
• Engine Controls-Key Switch, Throttle and Choke Controls	25	CH730S	CH730-0002	\$1,936.11	108
	27	CH740S	CH740-0002	\$2,128.42	108

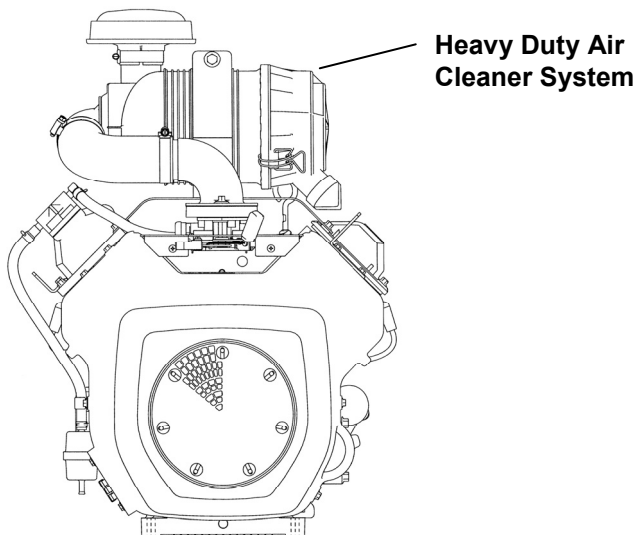

*50-State Emission Version

COMMAND PRO
25, 27, & 28 HP (Horizontal Shaft) V-Twin

Description	HP	Model	Spec. No.	List Price	Approx. Ship Wt. (lb.)
Standard Features Plus:					
• Crankshaft-1.125" (28.5 mm) Diameter x 4.0" (102 mm) PTO Length, 0.25" (6 mm) Keyway, Drilled and Tapped 1.5" (38 mm) Deep, 7/16-20 UNF					
• Engine Controls-Key Switch, Throttle and Choke Controls	25	CH730	CH730-3205	\$1,936.11	108
• 3/16" Evaporative emissions connection	27	CH740	CH740-3003	\$2,128.42	108
28 HP Electronic Fuel Injection (EFI) Model					
• Standard Features Like CH740-0060 Plus					
• 25 Amp					
• Includes Indicator Lamp and Terminals					
• Complete EFI System Less Muffler					
• Fixed Grass Screen Guard	28	CH745S	CH745-0010	\$2,790.29	115
• Standard Features Like CH745-0010 Plus 3/16" Evaporative emissions connection	28	CH745	CH745-3100	\$2,790.29	115

*50-State Emission Version

COMMAND PRO 30 HP (Horizontal Shaft) V-Twin

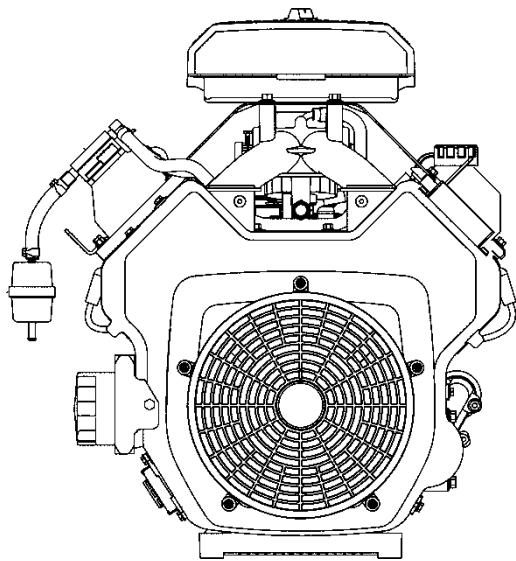
Description	HP	Model	Spec. No.	List Price	Approx. Ship Wt. (lb.)
Standard Features:					
<ul style="list-style-type: none"> • Overhead Valve Design • Hydraulic Valve Lifters • Digital Spark Advance System • Cast-Iron Cylinder Liners • PTO Sleeve Bearing (Side Load) • Electronic Ignition • Large Capacity Dual Element Air Cleaner • High Efficiency Grass Screen and Fan • Closed Breather System • Stellite® Exhaust Valves • Full Pressure Lubrication • Large Capacity In-Line Fuel Filter • Easy Access Valve Cover Oil Fill-Yellow • Oil Level Dipstick-Yellow • Large Capacity Oil Filter, Dual Oil Drain • Oil Sentry™ (Switch Installed and Wired but Unconnected) • Variable Speed Governor • Two-Barrel Carburetor • Fuel Shutdown Solenoid • Smart-Choke™ Carburetor • Mechanical Fuel Pump • High Performance Spark Plugs • 12 Volt Solenoid Shift Starter • Crankshaft-1.437" (36 mm) Diameter x 4.453" (113 mm) PTO Length, 0.375" (9.5 mm) Keyway, Drilled and Tapped 1.5" (38 mm) Deep, 5/8-18 UNF • PTO Face-5.625" (143 mm) Diameter, (4 Holes) 3/8-16 x 0.67" (17 mm) Deep, 7.75" (197 mm) Diameter, (4 Holes) 7/16-14 x 0.83" (21 mm) Deep • 7" (178 mm) Diameter Pilot • Color-Black with Cast Aluminum • See page 38 for Exhaust System Kits 					
					
Standard Features Plus:					
<ul style="list-style-type: none"> • Fixed Grass Screen Guard • 25 Amp Alternator, Regulated 	30	CH750S	CH750-0006	\$2,069.25	108
<ul style="list-style-type: none"> • Standard Features Like CH750-0006 Plus • 3/16" Evaporative emissions connection 	30	CH750	CH750-3006	\$2,069.25	108
Standard Features Plus:					
<ul style="list-style-type: none"> • Crankshaft-1.125" (28.5 mm) Diameter x 4.0" (102 mm) PTO Length, 0.25" (6 mm) Keyway, Drilled and Tapped 1.5" (38 mm) Deep, 7/16-20 UNF • Engine Controls-Key Switch, Throttle and Choke Controls • Fixed Grass Screen Guard • 25 Amp Alternator, Regulated 	30	CH750S	CH750-0005	\$2,130.88	108
<ul style="list-style-type: none"> • Standard Features Like CH750-0005 Plus • 3/16" Evaporative emissions connection 	30	CH750	CH750-3005	\$2,130.88	108

**COMMAND PRO CLOSED-LOOP EFI
27 & 29 HP (Horizontal Shaft) V-Twin**

Description	HP	Model	Spec. No.	List Price	Approx. Ship Wt. (lb.)
Standard Features:					
<ul style="list-style-type: none"> • Overhead Valve Design • Hydraulic Valve Lifters • Cast-Iron Cylinder Liners • PTO Sleeve Bearing (Side Load) • Electronic Ignition • Heavy Duty Canister Air Cleaner System (Kohler) • High Efficiency Grass Screen and Fan • Closed Breather System • Stellite® Exhaust Valves • Full Pressure Lubrication • In-Line Fuel Filter • Easy Access Valve Cover Oil Fill-Yellow • Oil Level Dipstick-Yellow • Large Capacity Oil Filter, Dual Oil Drain • Oil Sentry™ • Variable Speed Governor • Mechanical Fuel Pump • High Performance Spark Plugs • 12 Volt Solenoid Shift Starter • Crankshaft-1.125"(28.5 mm) Diameter x 4.0" (102 mm) PTO Length, 0.25" (6 mm) Keyway, Drilled and Tapped 1.5" (38 mm) Deep, 7/16-20 UNF • PTO Face-5.625" (143 mm) Diameter, (4 Holes) 3/8-16 x 0.67" (17 mm) Deep, 7.75" (197 mm) Diameter, (4 Holes) 7/16-14 x 0.83" (21 mm) Deep • 7" (178 mm) Diameter Pilot • Color-Black with Cast Aluminum • Engine Controls-Key Switch and Throttle Control • Fixed Grass Screen Guard • 20 Amp Alternator, Regulated • 3/16" Evaporative emissions connection • See page 38 for Exhaust System Kits 					
	27	ECH740	ECH740-3002	\$2,421.10	108
	29	ECH749	ECH749-3002	\$2,474.13	108
Standard Features Plus:					
<ul style="list-style-type: none"> • Crankshaft-1.437" (36.5 mm) Diameter x 4.46" (113 mm) PTO Length, 0.375" (9.5 mm) Keyway, Drilled and Tapped 1.5" (38 mm) Deep, 5/8-18 UNF 					
	27	ECH740	ECH740-3001	\$2,421.10	108

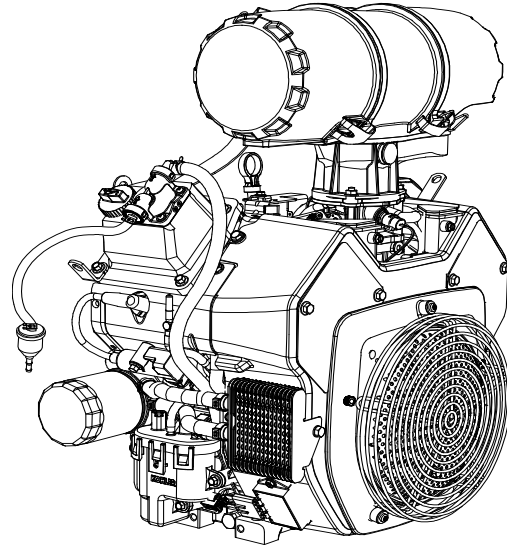

**COMMAND PRO CLOSED-LOOP EFI
19, 21, 25, 27 & 29 HP (Horizontal Shaft) V-Twin**

Description	HP	Model	Spec. No.	List Price	Approx. Ship Wt. (lb.)
Standard Features:					
<ul style="list-style-type: none"> • Overhead Valve Design • Hydraulic Valve Lifters • Cast-Iron Cylinder Liners • PTO Sleeve Bearing (Side Load) • Electronic Ignition • Large Capacity Dual Element Air Cleaner • High Efficiency Grass Screen and Fan • Closed Breather System • Stellite® Exhaust Valves • Full Pressure Lubrication • In-Line Fuel Filter • Easy Access Valve Cover Oil Fill-Yellow • Oil Level Dipstick-Yellow • Large Capacity Oil Filter, Dual Oil Drain • Oil Sentry™ • Variable Speed Governor • Mechanical Fuel Pump • High Performance Spark Plugs • 12 Volt Solenoid Shift Starter • Crankshaft-1.125"(28.5 mm) Diameter x 4.0" (102 mm) PTO Length, 0.25" (6 mm) Keyway, Drilled and Tapped 1.5" (38 mm) Deep, 7/16-20 UNF • PTO Face-5.625" (143 mm) Diameter, (4 Holes) 3/8-16 x 0.67" (17 mm) Deep, 7.75" (197 mm) Diameter, (4 Holes) 7/16-14 x 0.83" (21 mm) Deep • 7" (178 mm) Diameter Pilot • Color-Black with Cast Aluminum • Engine Controls-Key Switch and Throttle Control • Fixed Grass Screen Guard • 20 Amp Alternator, Regulated • 3/16" Evaporative emissions connection • See page 38 for Exhaust System Kits 					
	19	ECH630	ECH630-3001	\$1,672.83	108
	21	ECH650	ECH650-3001	\$1,872.58	108
	25	ECH730	ECH730-3002	\$2,110.70	108
Standard Features Plus:					
• Crankshaft-1.437" (36.5 mm) Diameter x 4.46" (113 mm) PTO Length, 0.375" (9.5 mm) Keyway, Drilled and Tapped 1.5" (38 mm) Deep, 5/8-18 UNF	21	ECH650	ECH650-3002	\$1,872.58	108
	25	ECH730	ECH730-3001	\$2,110.70	108
	27	ECH740	ECH740-3003	\$2,364.62	108
Standard Features Plus:					
• 25 Amp Alternator, Regulated	29	ECH749	ECH749-3001	\$2,422.78	108

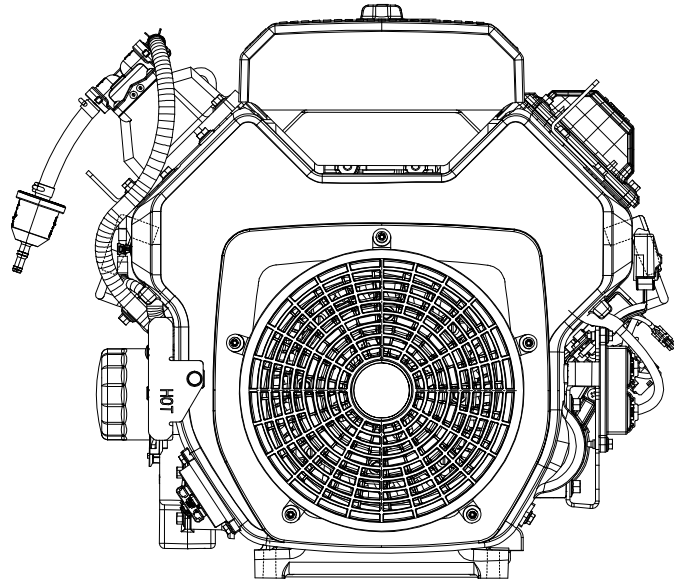

COMMAND PRO 30 HP (Horizontal Shaft) V-Twin

Description	HP	Model	Spec. No.	List Price	Approx. Ship Wt. (lb.)
Standard Features:					
<ul style="list-style-type: none"> • Overhead Valve Design • Hydraulic Valve Lifters • Digital Spark Advance System • Heavy Duty Canister Air Cleaner System • Fixed Grass Screen Guard • Cast-Iron Cylinder Liners • PTO Sleeve Bearing (Side Load) • Electronic Ignition • High Efficiency Grass Screen and Fan • Closed Breather System • Stellite® Exhaust Valves • Full Pressure Lubrication • Large Capacity In-Line Fuel Filter • Easy Access Valve Cover Oil Fill-Yellow • Oil Level Dipstick-Yellow • Large Capacity Oil Filter • Dual Oil Drain • Oil Sentry™ (Switch Installed and Wired but Unconnected) • Variable Speed Governor • Two-Barrel Carburetor • Fuel Shutdown Solenoid • Smart-Choke™ Carburetor • Mechanical Fuel Pump • High Performance Spark Plugs • 12 Volt Solenoid Shift Starter • 20 Amp Alternator, Regulated • Crankshaft-1.437" (36 mm) Diameter x 4.46" (113 mm) PTO Length, 0.375" (9.5 mm) Keyway, Drilled and Tapped 1.5" (38 mm) Deep, 5/8-18 UNF • PTO Face-5.625" (143 mm) Diameter, (4 Holes) 3/8-16 x 0.67" (17 mm) Deep, 7.75" (197 mm) Diameter, (4 Holes) 7/16-14 x 0.83" (21 mm) Deep • 7" (178 mm) Diameter Pilot • Color-Black with Cast Aluminum • See page 38 for Exhaust System Kits 					
	30	CH750S	CH750-0009	\$2,120.61	108
• Standard Features Like CH750-0009 Plus 3/16" Evaporative emissions connection	30	CH750	CH750-3009	\$2,120.61	108
Standard Features Plus:					
• Engine Controls-Key Switch, Throttle and Choke Controls					
• Kohler HDAC	30	CH750S	CH750-0008	\$2,182.23	108
• Standard Features Like CH750-0008 Plus 3/16" Evaporative emissions connection	30	CH750	CH750-3000	\$2,182.23	108

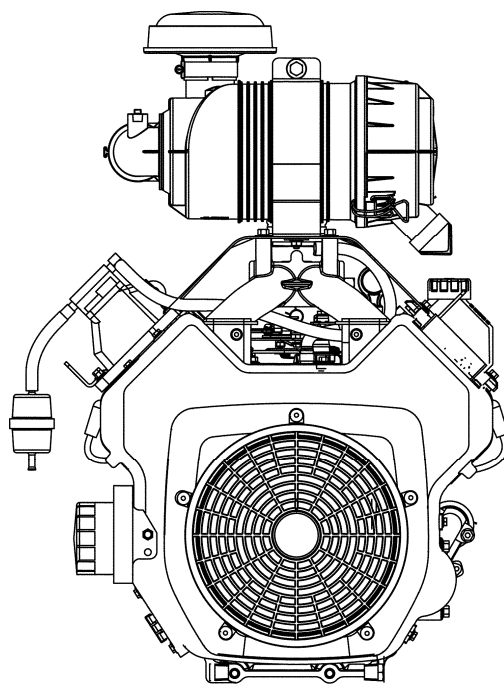

**COMMAND PRO
30 HP (Horizontal Shaft) V-Twin**

Description	HP	Model	Spec. No.	List Price	Approx. Ship Wt. (lb.)
Standard Features Plus:					
<ul style="list-style-type: none"> • Crankshaft-1.125" (28.5 mm) Diameter x 4.0" (102 mm) PTO Length, 0.25" (6 mm) Keyway, Drilled and Tapped 1.5" (38 mm) Deep, 7/16-20 UNF • Engine Controls-Key Switch, Throttle and Choke Controls • Kohler HDAC 					
• Standard Features Like CH750-0007 Plus	30	CH750S	CH750-0007	\$2,182.23	108
• 3/16" Evaporative emissions connection	30	CH750	CH750-3007	\$2,182.23	108

COMMAND PRO
34, 36, 38, & 40 HP (Horizontal Shaft) V-Twin

Description	HP	Model	Spec. No.	List Price	Approx. Ship Wt. (lb.)
Standard Features:					
<ul style="list-style-type: none"> • Overhead Valve Design • Hydraulic Valve Lifters • Nylon Cam Gear • Cast-Iron Cylinder Liners • Stellite® Exhaust Valves • Flywheel and PTO Sleeve Bearings • Electronic Ignition • High Performance Spark Plugs RFI and EMC Compliant • Full Pressure Lubrication • Top Mount Spin-On Large Capacity Oil Filter • Large Dual Oil Drains • Heavy Duty Canister Air Cleaner System • High Efficiency Grass Screen and Fan • Fixed Grass Screen Guard • Blower Housing with Removable Cylinder Access Covers • Easy Access Valve Cover Oil Fill-Yellow • Oil Level Dipstick-Yellow • Oil Sentry™ (Switch Installed but Unconnected) • Variable Speed Governor • Front Mounted Remote Controls (for boden wire connection) • Closed Breather System • Two-Barrel Carburetor • Fuel Shutdown Solenoid • Smart-Choke™ Carburetor • Mechanical Fuel Pump • Large Capacity In-Line Fuel Filter • 12 Volt Solenoid Shift Starter • 25 Amp Alternator, Regulated • Crankshaft-1.437" (36 mm) Diameter x 4.46" (113 mm) PTO Length, 0.375" (9.5 mm) Keyway, Drilled and Tapped 1.5" (38 mm) Deep, 5/8-18 UNF • PTO Face-5.625" (143 mm) Diameter, (4 Holes) 3/8-16 x 0.67" (17 mm) Deep, 7.75" (197 mm) Diameter, (4 Holes) 7/16-14 x 0.83" (21 mm) Deep • 7" (178 mm) Diameter Pilot • Color-Black with Cast Aluminum 					
	34	CH940S	CH940-0002	\$2,325.08	132
	36	CH960S	CH960-0002	\$2,495.09	132
	38	CH980S	CH980-0002	\$2,707.62	132
	40	CH1000S	CH1000-0002	\$3,005.15	132
Standard Features Plus:					
<ul style="list-style-type: none"> • 3/16" Evaporative emissions connection 					
	34	CH940	CH940-2002	\$2,325.08	132
	36	CH960	CH960-2002	\$2,495.09	132
	38	CH980	CH980-2002	\$2,707.62	132
	40	CH1000	CH1000-2002	\$3,005.15	132
Standard Features Plus:					
<ul style="list-style-type: none"> • Crankshaft-1.125" (28.5 mm) Diameter x 3.35" (85 mm) PTO Length 					
	34	CH940S	CH940-0003	\$2,364.35	132
	36	CH960S	CH960-0003	\$2,534.38	132
	38	CH980S	CH980-0003	\$2,746.89	132
Standard Features Plus:					
<ul style="list-style-type: none"> • Crankshaft-1.125" (28.5 mm) Diameter x 3.35" (85 mm) PTO Length • 3/16" Evaporative emissions connection 					
	34	CH940	CH940-2003	\$2,364.35	132
	36	CH960	CH960-2003	\$2,534.38	132
	38	CH980	CH980-2003	\$2,746.89	132

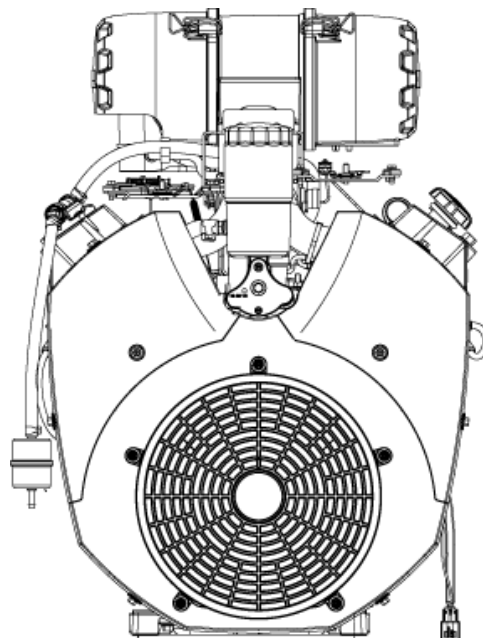

COMMAND PRO
34, 36, 38, & 40 HP (Horizontal Shaft) V-Twin

Description	HP	Model	Spec. No.	List Price	Approx. Ship Wt. (lb.)
Standard Features:					
<ul style="list-style-type: none"> • Overhead Valve Design • Hydraulic Valve Lifters • Nylon Cam Gear • Cast-Iron Cylinder Liners • Stellite® Exhaust Valves • Flywheel and PTO Sleeve Bearings • Electronic Ignition • High Performance Spark Plugs RFI and EMC Compliant • Full Pressure Lubrication • Top Mount Spin-On Large Capacity Oil Filter • Large Dual Oil Drains • Flat Air Cleaner • High Efficiency Grass Screen and Fan • Fixed Grass Screen Guard • Blower Housing with Removable Cylinder Access Covers • Easy Access Valve Cover Oil Fill-Yellow • Oil Level Dipstick-Yellow • Oil Sentry™ (Switch Installed but Unconnected) • Variable Speed Governor • Front Mounted Remote Controls (for boden wire connection) • Closed Breather System • Two-Barrel Carburetor • Fuel Shutdown Solenoid • Smart-Choke™ Carburetor • Mechanical Fuel Pump • Large Capacity In-Line Fuel Filter • 12 Volt Solenoid Shift Starter • 25 Amp Alternator, Regulated • Crankshaft-1.437" (36 mm) Diameter x 4.46" (113 mm) PTO Length, 0.375" (9.5 mm) Keyway, Drilled and Tapped 1.5" (38 mm) Deep, 5/8-18 UNF • PTO Face-5.625" (143 mm) Diameter, (4 Holes) 3/8-16 x 0.67" (17 mm) Deep, 7.75" (197 mm) Diameter, (4 Holes) 7/16-14 x 0.83" (21 mm) Deep • 7" (178 mm) Diameter Pilot • Color-Black with Cast Aluminum 					
	34	CH940S	CH940-0005	\$2,313.18	132
	36	CH960S	CH960-0005	\$2,483.19	132
	38	CH980S	CH980-0005	\$2,695.71	132
Standard Features Plus:					
• 3/16" Evaporative emissions connection	34	CH940	CH940-2005	\$2,313.18	132
	38	CH980	CH980-2005	\$2,695.71	132
Standard Features Plus:					
Mud Boat Spec					
• Crankshaft-1.125" (28.5 mm) Diameter x 4.00" (101.6 mm) PTO Length					
• Remote Throttle Manual Choke (Engine Mounted Key Switch					
• Canister Muffler PTO Outlet (62 786 01-S Installed)	40	CH1000S	CH1000-0012	\$3,047.50	132
• Standard Features Like CH1000-0012 Plus 3/16" Evaporative emissions connection	40	CH1000	CH1000-2012	\$3,047.50	132

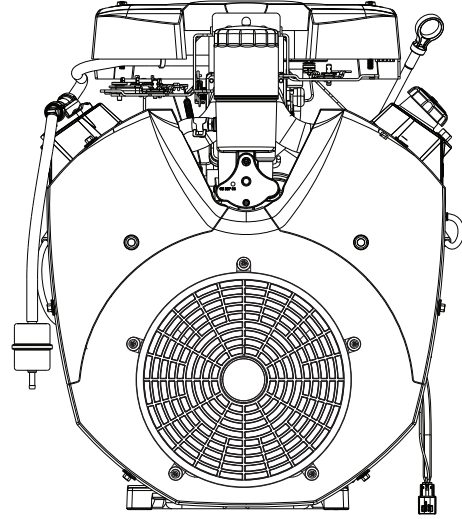

Control Kit and Exhaust System Kits

Kit/Part No.	Description	List Price
62 376 02-S	Engine Mounted Control Kit (Includes Key Switch, Panel, Oil Sentry Light, Decal Knobs, Brackets, and Screws).....	\$72.77
62 786 01-S	PTO Canister Muffler Kit-Center Outlet (Includes Muffler)	\$116.39
62 786 02-S	PTO Canister Muffler Kit-Starter Side Outlet (Includes Muffler)	\$116.39
62 786 03-S	PTO Canister Muffler Kit-Opposite Starter Side Outlet (Includes Muffler).....	\$116.39

COMMAND
18 HP (Horizontal Shaft) V-Twin

Description	HP	Model	Spec. No.	List Price	Approx. Ship Wt. (lb.)
Standard Features:					
<ul style="list-style-type: none"> • Overhead Valve Design • Hydraulic Valve Lifters • Electronic Ignition • Dual Element Air Cleaner • Closed Breather System • Stellite® Exhaust Valves • Cast Iron Cylinder Liners • Full Pressure Lubrication • In-Line Fuel Filter • Easy Access Valve Cover Oil Fill • Oil Level Dipstick • Oil Filter • Dual Oil Drain • Oil Sentry™ (Switch Installed and Wired but Unconnected) • Variable Speed Governor • Fuel Shutdown Solenoid • Smart-Choke™ Carburetor • Mechanical Fuel Pump • 12 Volt Solenoid Shift Starter • 15 Amp Alternator, Regulated • Crankshaft-1.125" (28.5 mm) Diameter x 4.0" (102 mm) PTO Length, 0.25" (6 mm) Keyway, Drilled and Tapped 1.5" (38 mm) Deep, 7/16-20 UNF • PTO Face-5.625" (143 mm) Diameter, (4 Holes) 3/8-16 x 0.67" (17 mm) Deep, 7.75" (197 mm) Diameter, (4 Holes) 7/16-14 x 0.83" (21 mm) Deep • 7" (178 mm) Diameter Pilot • Color-Black with Cast Aluminum 					
• See page 38 for Exhaust System Kits/Parts	18	CH18S	62500	\$1,346.69	106
Standard Features Plus:					
• 3/16" Evaporative emissions connection	18	CH620	CH620-3002	\$1,346.69	106
Standard Features Plus:					
• Engine Controls-Key Switch, Throttle and Choke Controls (Pro version 62587)	18	CH18S	62501	\$1,380.15	106
• Standard Feature Like 62501 Plus 3/16" Evaporative emissions connection	18	CH620	CH620-3003	\$1,380.15	106
Standard Features Plus:					
• Crankshaft-1" (25.4 mm) Diameter x 3.0" (76 mm) PTO Length, 0.25" (6 mm) Keyway, Drilled and Tapped 1" (25.4 mm) Deep, 3/8-24 UNF					
• PTO Face-5" (127 mm) Diameter, (4 Holes) 5/16-24 x 0.67" (17 mm) Deep, 6.5" (165 mm) Diameter, (4 Holes) 3/8-16 x 0.83" (21 mm) Deep, 7.75" (197 mm) Diameter (4 Holes) 7/16-14 x 0.83" (21 mm) Deep	18	CH18S	62502	\$1,346.69	106
• 5.75" (146 mm) Diameter Pilot					
• Standard Features Like 62502 Plus 3/16" Evaporative emissions connection	18	CH620	CH620-3005	\$1,346.69	106

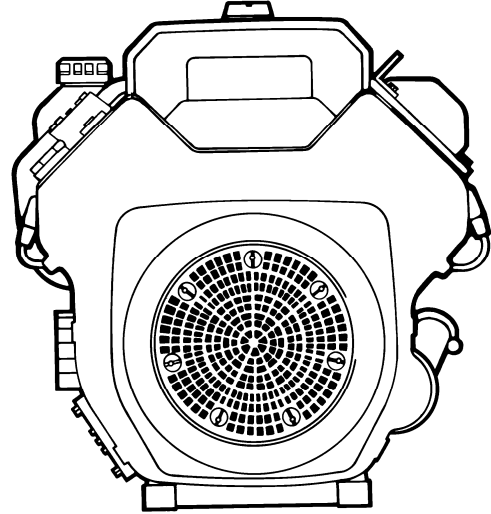

COMMAND
18 HP (Horizontal Shaft) V-Twin

Description	HP	Model	Spec. No.	List Price	Approx. Ship Wt. (lb.)
Standard Features Plus:					
<ul style="list-style-type: none"> • Engine Controls-Key Switch, Throttle and Choke Controls • Crankshaft-1" (25.4 mm) Diameter x 3.0" (76 mm) PTO Length, 0.25" (6 mm) Keyway, Drilled and Tapped 1" (25.4 mm) Deep, 3/8-24 UNF • PTO Face-5" (127 mm) Diameter, (4 Holes) 5/16-24 x 0.67" (17 mm) Deep, 6.5" (165 mm) Diameter, (4 Holes), 3/8-16, 7.75" (197 mm) Diameter, (4 Holes) 7/16-14 x 0.83" (21 mm) Deep 	18	CH18S	62503	\$1,380.15	106
<ul style="list-style-type: none"> • 5.75" (146 mm) Diameter Pilot • Standard Features Like 62503 Plus 3/16" Evaporative emissions connection 	18	CH620	CH620-3004	\$1,380.15	106
Standard Features Plus:					
<ul style="list-style-type: none"> • Crankshaft-2.25" (57.15 mm) Per Foot (305 mm) Taper, 1.5" (38 mm) Diameter x 3.94" (100.1 mm) PTO Length, Drilled and Tapped 0.625" (16 mm) Deep, 5/16-24 UNF • PTO Face-5.625" (143 mm) Diameter (4 Holes) 3/8-16 x 0.67" (17 mm) Deep, 7.75" (197 mm) Diameter, (4 Holes) 7/16-14 x 0.83" (21 mm) Deep • 6.437" (163 mm) Diameter Pilot • Oil Sentry™ Wired for Shutdown • Fixed Grass Screen Guard • Engine Controls-Key Switch and Choke Control • 5% Governor Regulation • Constant Speed @ 3200 RPM 	18	CH18GS	62504	\$1,462.52	107
<ul style="list-style-type: none"> • Standard Features Like 62504 Plus 3/16" Evaporative emissions connection 	18	CH620	CH620-3007	\$1,462.52	107
Standard Features Plus:					
<ul style="list-style-type: none"> • Engine Controls-Key Switch, Throttle and Choke Controls • Retractable Start Backup • Crankshaft-1" (25.4 mm) Diameter x 3.0" (76.2 mm) PTO Length, 0.25" (6 mm) Keyway, Drilled and Tapped 1" (25.4 mm) Deep, 3/8-24 UNF • PTO Face-5" (127 mm) Diameter, (4 Holes) 5/16-24 x 0.67" (17 mm) Deep, 6.5" (165 mm) Diameter, (4 Holes) 3/8-16 x 0.83" (21 mm) Deep, 7.75" (197 mm) Diameter, (4 Holes) 7/16-14 x 0.83" (21 mm) Deep 	18	CH18ST	62505	\$1,428.95	106
<ul style="list-style-type: none"> • 5.75" (146 mm) Diameter Pilot • Standard Features Like 62505 Plus 3/16" Evaporative emissions connection 	18	CH620	CH620-3009	\$1,428.95	106

COMMAND
18 HP (Horizontal Shaft) V-Twin

Description	HP	Model	Spec. No.	List Price	Approx. Ship Wt. (lb.)
Standard Features Plus:					
• Engine Controls-Key Switch, Throttle and Choke Controls					
• Anti-Icing Features with Starter Side Exhaust System					
• Fixed Grass Screen Guard					
• Round Air Cleaner with Snorkel to Starter Side Muffler	18	CH18S	62507	\$1,520.87	106
• Standard Features Like 62507 Plus 3/16" Evaporative emissions connection	18	CH620	CH620-3006	\$1,520.87	106

Aegis and Command Exhaust System Kits/Parts

Kit/Part No.	Description	List Price (each)
24 786 04-S	PTO Canister Muffler Kit-Center Outlet (CH18-22)	\$101.74
24 786 05-S	PTO Canister Muffler Kit-Filter Side Outlet (CH18-22).....	\$101.74
24 786 06-S	PTO Canister Muffler Kit-Starter Side Outlet (CH18-22).....	\$101.74
24 786 08-S	Side Mount Muffler Kit-Starter Side (CH18-22)	\$173.64
24 786 09-S	Side Mount Muffler Kit-Filter Side (CH18-22).....	\$173.64
24 786 10-S	PTO Canister Muffler Kit-Center Outlet (CH25/CH730/CH740, LH640-755).....	\$131.32
24 786 11-S	PTO Canister Muffler Kit-Filter Side Outlet (CH25/CH730/CH740, LH640-755)	\$131.32
24 786 12-S	PTO Canister Muffler Kit-Starter Side Outlet (CH25/CH730/CH740, LH640-755)....	\$125.07
24 786 13-S	Valve Cover Mounting Muffler Kit-Starter Side (for "00" spec. variation) (CV18-22).	\$190.15
24 786 14-S	Valve Cover Mounting Muffler Kit-Filter Side (for "00" spec. variation) (CV18-22) ...	\$186.35
24 786 19-S	Side Mount Muffler Kit-Starter Side (CH25/CH730/CH740, LH640-755).....	\$214.99
24 786 20-S	Side Mount Muffler Kit-Filter Side (CH25/CH730/CH740, LH640-755).....	\$238.54
24 786 21-S	Raised Body PTO Canister Kit-Filter Side Outlet (CH18-740, LH640-755)	\$155.20
24 786 22-S	Raised Body PTO Canister Kit-Starter Side Outlet (CH18-740, LH640-755)	\$155.20
25 755 36-S	Mounting Kit, Canister Muffler (CH745, LH775).....	\$29.33
24 786 24-S	Side Mount Muffler Kit - Starter Side (CH745, LH775).....	\$170.91
24 786 25-S	Side Mount Muffler Kit - Filter Side (CH745, LH775)	\$170.91
24 786 28-S	Muffler Kit – Starter Side (Command EFI Verticals).....	\$149.85
24 786 29-S	Muffler Kit – Filter Side (Command EFI Verticals).....	\$149.85
24 786 30-S	Muffler Kit – Filter Side Down (Command EFI Verticals).....	\$201.80
24 786 31-S	Muffler Kit – Starter Side (Command EFI Horizontals).....	\$118.90
24 786 32-S	Muffler Kit – Filter Side (Command EFI Horizontals).....	\$118.95
24 786 33-S	Muffler Kit – Center Outlet (Command EFI Horizontals).....	\$118.00

**COMMAND
20 HP (Horizontal Shaft) V-Twin**

Description	HP	Model	Spec. No.	List Price	Approx. Ship Wt. (lb.)
Standard Features:					
<ul style="list-style-type: none"> • Overhead Valve Design • Hydraulic Valve Lifters • Electronic Ignition • Dual Element Air Cleaner • Closed Breather System • Stellite® Exhaust Valves • Cast Iron Cylinder Liners • Full Pressure Lubrication • In-Line Fuel Filter • Easy Access Valve Cover Oil Fill • Oil Level Dipstick • Oil Filter • Dual Oil Drain • Oil Sentry™ (Switch Installed and Wired but Unconnected) • Variable Speed Governor • Fuel Shutdown Solenoid • Smart-Choke™ Carburetor • Mechanical Fuel Pump • 12 Volt Solenoid Shift Starter • 15 Amp Alternator, Regulated • Crankshaft-1.437" (36 mm) Diameter x 4.41" PTO Length, 0.375" (9.5 mm) Keyway, Drilled and Tapped 1.5" (38 mm) Deep, 5/8-18 UNF • PTO Face-5.625" (143 mm) Diameter, (4 Holes) 3/8-16 x 0.67" (17 mm) Deep, 7.75" (197 mm) Diameter, (4 Holes) 7/16-14 x 0.83" (21 mm) Deep • 7" (178 mm) Diameter Pilot • Color-Black with Cast Aluminum • See page 38 for Exhaust System Kits/Parts 					
	20	CH20S	64500	\$1,545.55	106
Standard Features Plus:					
<ul style="list-style-type: none"> • Standard Features Like 64500 Plus 3/16" Evaporative emissions connection 					
	20	CH640	CH640-3006	\$1,545.55	106
Standard Features Plus:					
<ul style="list-style-type: none"> • Engine Controls-Key Switch, Throttle and Choke Controls (Pro version 64594) 					
	20	CH20S	64501	\$1,579.91	106
<ul style="list-style-type: none"> • Standard Features Like 64501 Plus 3/16" Evaporative emissions connection 					
	20	CH640	CH640-3002	\$1,579.91	106
Standard Features Plus:					
<ul style="list-style-type: none"> • Engine Controls-Key Switch, Throttle and Choke Controls • Crankshaft-1.125" (28.5 mm) Diameter x 4.0" (102 mm) PTO Length, 0.25" (6 mm) Keyway, Drilled and Tapped 1.5" (38 mm) Deep, 7/16-20 UNF (Pro version 64595) 					
	20	CH20S	64503	\$1,579.91	106
<ul style="list-style-type: none"> • Standard Features Like 64503 Plus 3/16" Evaporative emissions connection 					
	20	CH640	CH640-3004	\$1,579.91	106

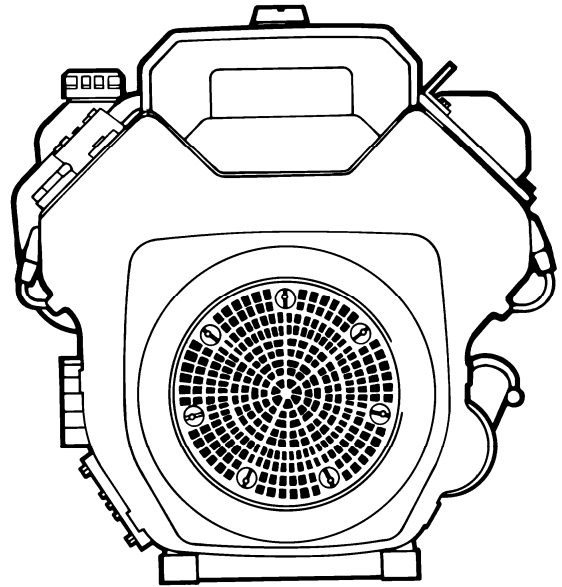

**AEGIS® LIQUID-COOLED
24-31 HP (Horizontal Shaft) V-Twin**

Description	HP	Model	Spec. No.	List Price	Approx. Ship Wt. (lb.)
-------------	----	-------	--------------	---------------	---------------------------

Standard Features:

- Liquid-Cooled with High Efficiency Radiator
- Overhead Valve Design
- Hydraulic Valve Lifters
- Electronic Ignition
- Cast-Iron Cylinder Liners
- PTO Sleeve Bearing (Side Load)
- Heavy Duty, Dual Element Commercial Air Cleaner
- Closed Breather System
- Debris Screen
- Stellite® Exhaust Valves, with Seat Inserts
- Full Pressure Lubrication
- Large Capacity In-Line Fuel Filter
- Easy Access Oil Fill and Dipstick Location-Yellow
- Large Capacity Oil Filter
- Dual Oil Drain
- Oil Sentry™ (Switch Installed and Wired but Unconnected)
- Accepts Command Twin PTO Mount Muffler
- High Mount Controls for Boden Wires
- Variable Speed Governor
- High Performance Accelerator Pump Carburetor
- Fuel Shutdown Solenoid
- Smart-Choke™ Carburetor
- Mechanical Fuel Pump (Oil Filter Side Valve Cover)
- High Performance Spark Plugs
- 12 Volt Solenoid Shift Starter
- 20 Amp Alternator, Regulated
- Crankshaft-1.437" (36.5 mm) Diameter x 4.46" (113 mm)
PTO Length, 0.375" (9.5 mm) Keyway, Drilled and Tapped 1.5"
(38 mm) Deep, 5/8-18 UNF
- PTO Face-5.625" (143 mm) Diameter,
(4 Holes) 3/8-16 x 0.67" (17 mm) Deep, 7.75" (197 mm) Diameter,
(4 Holes) 7/16-4 x 0.83" (21 mm) Deep
- 7" (178 mm) Diameter Pilot
- Color-Black with Cast Aluminum
- See page 38 For Exhaust System Kits/Parts

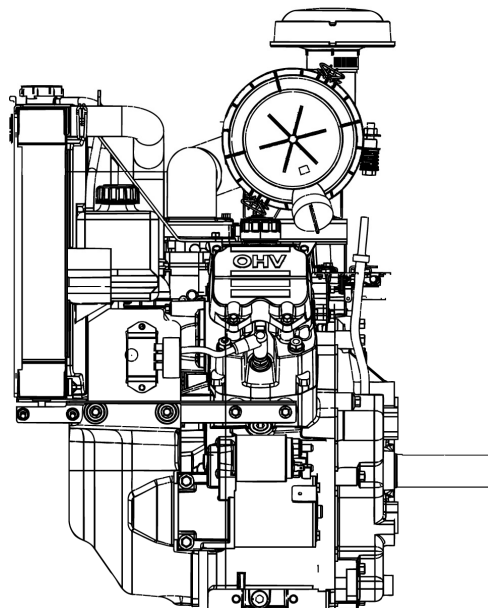

Standard Features Plus:

- | | | | | | |
|---|----|--------|------------|------------|-----|
| • Engine Mounted Controls (Oil Filter Side).
Includes Throttle, Choke Lever, Key Switch, Oil
Sentry™ Light. | 26 | LH690S | LH690-0003 | \$2,144.04 | 130 |
| | 28 | LH755S | LH755-0003 | \$2,205.42 | 130 |

31 HP Electronic Fuel Injection (EFI) Model:

- | | | | | | |
|---|----|--------|------------|------------|-----|
| • Standard Features Like LH755-0001 Plus:
• Complete EFI System Less Muffler | 31 | LH775S | LH775-0001 | \$2,845.14 | 130 |
|---|----|--------|------------|------------|-----|

**DIESEL AIR-COOLED
KD350 (Single Cylinder) 6.7 HP (5 kW)**

Description	Old Spec Number	Model	Spec. No.	List Price	Approx. Ship Wt. (lb.)
Standard Features:					
<ul style="list-style-type: none"> • 1" Diameter Integral Keyed Shaft (Ext 4) • Internal Oil Filter • Dry Type Air Cleaner • Inline Fuel Filter • 4.3 L Fuel Tank • Muffler w/Guard • 3600 rpm • SAE J609a Flanges A/B • Manual Throttle and Stop Controls • Fuel Valve Safety Shutdown for Low Oil Pressure (Electric Start Only) 					
					
Standard Features Plus:					
• Recoil Start	ED3B32E0	KD350	KD350-1001	\$1,698.82	120
Standard Features Plus:					
<ul style="list-style-type: none"> • 12 Volt Electric Start • Control Panel with Integral Voltage Regulator • 12A Alternator @ 3600 rpm 					
		KD350	KD350-2001	\$1,914.13	120
Standard Features Plus:					
<ul style="list-style-type: none"> • Recoil Start • Generator Crankshaft (Ext 6) 					
	ED6B55E0	KD350	KD350-3001	\$1,741.70	120
Standard Features Plus:					
<ul style="list-style-type: none"> • 12 Volt Electric Start • Control Panel with Integral Voltage Regulator • 12A Alternator @ 3600 rpm • Generator Crankshaft (Ext 6) 					
	ED6B56E0	KD350	KD350-4001	\$1,957.22	120
Standard Features Plus:					
<ul style="list-style-type: none"> • Recoil Start • 5/8" Threaded Crankshaft (Ext 7) 					
		KD350	KD350-5001	\$1,741.70	120
Standard Features Plus:					
<ul style="list-style-type: none"> • 12 Volt Electric Start • Control Panel with Integral Voltage Regulator • 12A Alternator @ 3600 rpm • 5/8" Threaded Crankshaft (Ext 7) 					
		KD350	KD350-6001	\$1,957.22	120
Standard Features Plus:					
<ul style="list-style-type: none"> • Recoil Start • 3/4" Crankshaft (Ext 3) 					
	ED3B49E0	KD350	KD350-7001	\$1,957.22	120
Standard Features Plus:					
<ul style="list-style-type: none"> • 12 Volt Electric Start • 12A Alternator @ 3600 rpm • 3/4" Crankshaft (Ext 3, Pacer Spec) 					
Less: Control Panel, Wiring Harness and Fuel Valve Safety Shutdown for Low Oil Pressure					
		KD350	KD350-8001	\$1,957.22	120

Note: Orders will be filled with old spec number until stock is depleted.

**DIESEL AIR-COOLED
KD400 (Single Cylinder) 9.8 HP (7.3 kW)**

Description	Old Spec Number	Model	Spec. No.	List Price	Approx. Ship Wt. (lb.)
Standard Features:					
<ul style="list-style-type: none"> • 1" Diameter Integral Keyed Shaft (Ext 4) • Internal Oil Filter • Dry Type Air Cleaner • Inline Fuel Filter • 5 L Fuel Tank • Muffler w/Guard • 3600 rpm • SAE J609a Flange B • Manual Throttle and Stop Controls • Control Panel • Fuel Valve Safety Shutdown for Low Oil Pressure (Electric Start Only) 					
					
Standard Features Plus:					
• Recoil Start		KD400	KD400-1001		125
Standard Features Plus:					
• 12 Volt Electric Start					
• 20 Amp Alternator @ 3600 rpm		KD400	KD400-2001		125
Standard Features Plus:					
• Recoil Start					
• 1" Threaded Crankshaft (Ext 9)		KD400	KD400-3001		125
Standard Features Plus:					
• 12 Volt Electric Start					
• 12A Alternator, Control Panel with Integral Voltage Regulator					
• 1" Threaded Crankshaft (Ext 9)					
Less: Fuel Valve Safety Shutdown for Low Oil Pressure	ED3A84E3	KD400	KD400-4001	\$2,207.91	125
Standard Features Plus:					
• 12 Volt Electric Start					
• 12A Alternator, Control Panel with Integral Voltage Regulator					
• Generator Crankshaft (Ext 6)		KD400	KD400-6001		125

Note: Orders will be filled with old spec number until stock is depleted.

Note: The KD400 model has been replaced with the KD420 model.

DIESEL AIR-COOLED
KD420 (Single Cylinder) 9.8 HP (7.3 kW)

Description	Model	Spec. No.	List Price	Approx. Ship Wt. (lb.)
Standard Features:				
<ul style="list-style-type: none"> • 1" Diameter Integral Keyed Shaft (Ext 4) • Balance Shaft • Internal Oil Filter • Dry Type Air Cleaner • Inline Fuel Filter • 5 L Fuel Tank • Muffler w/Guard • 3600 rpm • SAE J609a Flange B • Manual Throttle and Stop Controls • Fuel Valve Safety Shutdown for Low Oil Pressure (Electric Start Only) • EGR (Exhaust Gas Recirculation) • Tier 4 compliant (Hand start provision) 				
				
Standard Features Plus:				
• Recoil Start	KD420	KD420-1001	\$1,908.06	125
Standard Features Plus:				
• 12 Volt Electric Start				
• 20 Amp Alternator @ 3600 rpm	KD420	KD420-2001	\$2,213.82	125
Standard Features Plus:				
• 12 Volt Electric Start				
• 20 Amp Alternator @ 3600 rpm				
• Control panel with auto glow plug timer				
• Glow plugs	KD420	KD420-2101	\$2,317.04	125
Standard Features Plus:				
• Recoil Start				
• 1" Threaded Crankshaft (Ext 9)	KD420	KD420-3001	\$1,997.20	125
Standard Features Plus:				
• 12 Volt Electric Start				
• 12A Alternator, Control Panel with Integral Voltage Regulator				
• Manual shut down				
• 1" Threaded Crankshaft (Ext 9)				
Less: Safety Shutdown for Low Oil Pressure	KD420	KD420-4001	\$2,256.68	125
Standard Features Plus:				
• 12 Volt Electric Start				
• 12A Alternator, Control Panel with Integral Voltage Regulator				
• Manual shut down				
• Conical Crankshaft				
Less: Safety Shutdown for Low Oil Pressure	KD420	KD420-5001	\$2,017.79	125
Standard Features Plus:				
• 12 Volt Electric Start				
• 12A Alternator, Control Panel with Integral Voltage Regulator				
• Generator Crankshaft				
Less: fuel tank	KD420	KD420-6001	\$2,367.25	125
Standard Features Plus:				
• 12 Volt Electric Start				
• 20 Amp Alternator @ 3600 rpm				
Less: fuel tank	KD420	KD420-7002	\$2,371.00	125

**DIESEL AIR-COOLED
KD477-2 (Twin Cylinder) 17.2 HP (12.8 kW)**

Description	Old Spec Number	Model	Spec. No.	List Price	Approx. Ship Wt. (lb.)
Standard Features:					
<ul style="list-style-type: none"> • 12 Volt Starter with 18 Amp Alternator • Deluxe Electric Control Panel • Glow Plugs (Cold Start Aid) • Safety Shutdown for Low Oil Pressure with High Temp Cylinder Head Shutdown • Electric Shutdown Solenoid • Oil Filter • Muffler with Guard • Oil Bath Air Cleaner w Pre-cleaner • Fuel Filter • Throttle & Stop Control Lever • Standard Mounting Feet • 2700 rpm 					
					
Standard Features Plus:					
Standard Industrial Spec					
• 1-1/8" Keyed Shaft w 7.0" Flange		KD477-2	KD4772-1001	\$4,009.20	245
Standard Features Plus:					
Hydraulic Pump Spec					
• SAE 2A-9T (Installed)		KD477-2	KD4772-2001	\$4,164.18	245
Standard Features Plus:					
Standard Industrial Spec					
• SAE 5 housing and 6 1/2" flywheel	ED4A97E1	KD477-2	KD4772-3001	\$4,015.59	245
Note: Orders will be filled with old spec number until stock is depleted.					

**DIESEL AIR-COOLED
KD625-2 (Twin Cylinder) 25.2 HP (18.8 kW)**

Description	Model	Spec. No.	List Price	Approx. Ship Wt. (lb.)
Standard Features:				
<ul style="list-style-type: none"> • 12 Volt Starter with 18 Amp Alternator • Electric Control Panel • Oil Bath Air Cleaner w/Pre-cleaner • Manifold Horizontal Muffler • Lube Oil Filter • Fuel Filter with QSD Solenoid • Manual Throttle & Stop Lever Control • Group 8 housing & flywheel • Fuel Lift Pump • Standard Engine Mounting Feet • 3000 rpm 				
				
Standard Features Plus:				
	KD625-2	KD6252-1001	\$4,237.71	290
Standard Features Plus:				
<ul style="list-style-type: none"> • With 10 L Fuel Tank • 14 A Alternator 				
Less: QSD Solenoid	KD625-2	KD6252-2001	\$4,391.47	290

**DIESEL LIQUID-COOLED
KDW702 (Twin Cylinder) 16.8 HP (12.5 kW)**

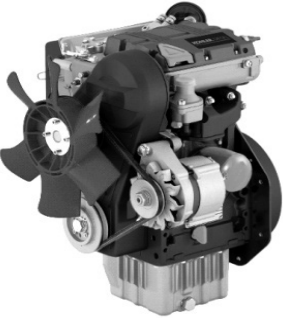
Description	Old Spec Number	Model	Spec. No.	List Price	Approx. Ship Wt. (lb.)
Standard Features:					
<ul style="list-style-type: none"> • Mounted Top Tank Radiator • Radiator Fan Guard • Mounted Air Cleaner • Muffler • Muffler Guard • 12 Volt Electric Starter Motor with 45 Amp External Alternator • Glow Plugs (Cold Start Aid) • Fuel Filter with valve • Mounting Feet • Mounted Control Panel • 3600 RPM • Safety shutdown for low oil pressure/high coolant temp 					
					
Standard Features Plus:					
<ul style="list-style-type: none"> • High Speed 3600 RPM • Suction Fan • Group 8 housing and flywheel 					
		KDW702	KDW702-1001	\$4,125.49	260
Standard Features Plus:					
<ul style="list-style-type: none"> • 7 mm back plate 					
		KDW702	KDW702-1101	\$4,087.00	235
Standard Features Plus:					
<ul style="list-style-type: none"> • Low Speed 1800 RPM • Pusher Fan • SAE 5 housing and 6 ½" flywheel 					
		KDW702	KDW702-2001	\$4,163.31	260
Standard Features Plus:					
<ul style="list-style-type: none"> • Gen Speed 3600 RPM • Pusher Fan • SAE 5 housing and 6 ½" flywheel 					
	ED6A77E0	KDW702	KDW702-4001	\$4,163.31	260
Standard Features Plus:					
<ul style="list-style-type: none"> • Fan to Flywheel High Speed 3600 RPM • less radiator • less Air Cleaner • less Muffler • less Control Panel • Suction Fan • 12 Volt Electric Starter Motor with 45 Amp external Alternator • 7 mm back plate 					
		KDW702	KDW702-1201		150

Note: Orders will be filled with old spec number until stock is depleted.

**DIESEL LIQUID-COOLED
KDW1003 (3 Cylinder) 26.1 HP (19.5 kW)**

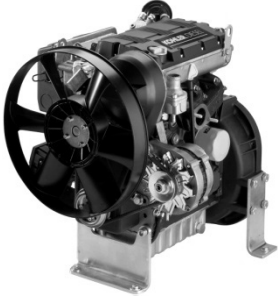
Description	Model	Spec. No.	List Price	Approx. Ship Wt. (lb.)
Standard Features:				
<ul style="list-style-type: none"> • Mounted Top Tank Radiator • Radiator Fan Guard • Mounted Air Cleaner • Muffler • Muffler Guard • 12 Volt Electric Starter Motor with 45 Amp External Alternator • Glow Plugs (Cold Start Aid) • Fuel Filter with valve • Mounting Feet • Mounted Control Panel • 3600 RPM • Safety shutdown for low oil pressure/high coolant temp 				
<hr/>				
Standard Features Plus:				
<ul style="list-style-type: none"> • High Speed 3600 RPM • Suction Fan • Group 8 housing and flywheel 	KDW1003	KDW1003-1001	\$4,409.54	320
<hr/>				
Standard Features Plus:				
<ul style="list-style-type: none"> • 7 mm back plate 	KDW1003	KDW1003-1101	\$4,243.46	295
<hr/>				
Standard Features Plus:				
<ul style="list-style-type: none"> • Low Speed 1800 RPM • Pusher Fan • SAE 5 housing and 6 1/2" flywheel 	KDW1003	KDW1003-2001	\$4,409.54	320
<hr/>				
Standard Features Plus:				
<ul style="list-style-type: none"> • Gen Speed 3600 RPM • Pusher Fan • SAE 5 housing and 6 1/2" flywheel 	KDW1003	KDW1003-3001	\$4,409.54	320
<hr/>				
Standard Features Plus:				
<ul style="list-style-type: none"> • Fan to Flywheel High Speed 3600 RPM • less radiator • less Air Cleaner • less Muffler • less Control Panel • Suction Fan • 12 Volt Electric Starter Motor with 45 Amp external Alternator • 7 mm back plate 	KDW1003	KDW1003-1201	\$4,067.15	190

**DIESEL LIQUID-COOLED
KDW1404 (4 Cylinder) 34.9 HP (26 kW)**

Description	Model	Spec. No.	List Price	Approx. Ship Wt. (lb.)
Standard Features:				
<ul style="list-style-type: none"> • Mounted Top Tank Radiator • Radiator Fan Guard • Mounted Air Cleaner • Muffler • Muffler Guard • 12 Volt Electric Starter Motor with 45 Amp External Alternator • Glow Plugs (Cold Start Aid) • Fuel Filter with valve • Mounting Feet • Mounted Control Panel • Safety shutdown for low oil pressure/high coolant temp 				
				
Standard Features Plus:				
<ul style="list-style-type: none"> • High Speed 3600 RPM • Suction Fan • Group 8 housing and flywheel 				
	KDW1404	KDW1404-1001	\$5,438.45	350
Standard Features Plus:				
<ul style="list-style-type: none"> • Low Speed 1800 RPM • Pusher Fan • SAE 5 housing and 6 ½" flywheel 				
	KDW1404	KDW1404-2001	\$5,438.45	350
Standard Features Plus:				
<ul style="list-style-type: none"> • Gen Speed 3600 RPM • Pusher Fan • SAE 5 housing and 6 ½" flywheel 				
	KDW1404	KDW1404-3001	\$5,052.37	350

**DIESEL LIQUID-COOLED
KDW1603 (3 Cylinder) 40.2 HP (30 kW)**

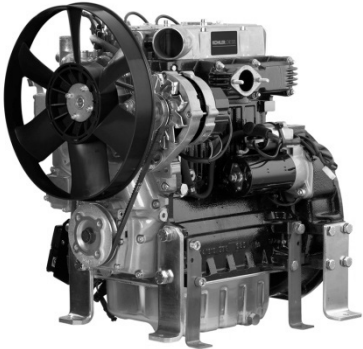
Description	Old Spec Number	Model	Spec. No.	List Price	Approx. Ship Wt. (lb.)
Standard Features:					
<ul style="list-style-type: none"> • Mounted Top Tank Radiator <ul style="list-style-type: none"> • Radiator Fan Guard • Mounted Air Cleaner • Muffler • Muffler Guard • 12 Volt Electric Starter Motor with 45 Amp External Alternator • Glow Plugs (Cold Start Aid) • Fuel Filter with valve • Mounting Feet • Mounted Control Panel • Also includes Safety shutdown for low oil pressure/high coolant temp 					
					
Standard Features Plus:					
<ul style="list-style-type: none"> • High Speed 3000 RPM • Suction Fan • Group 5 housing and flywheel 					
		KDW1603	KDW1603-1001	\$5,700.12	488
Standard Features Plus:					
<ul style="list-style-type: none"> • Low Speed 1800 RPM • Pusher Fan • SAE 5 housing and 7 ½" flywheel 					
	ED6B05E0	KDW1603	KDW1603-2001	\$5,700.12	488
Note: Orders will be filled with old spec number until stock is depleted.					

**DIESEL LIQUID-COOLED
KDW2204 (4 Cylinder) 51 HP (38 kW)**

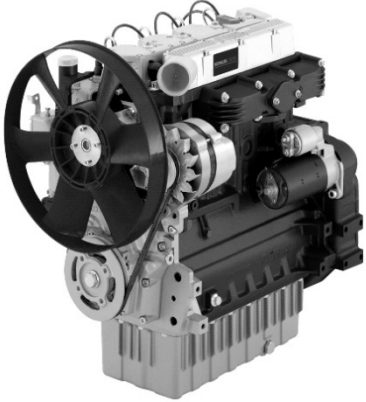
Description	Old Spec Number	Model	Spec. No.	List Price	Approx. Ship Wt. (lb.)
Standard Features:					
<ul style="list-style-type: none"> • Mounted Top Tank Radiator • Radiator Fan Guard • Mounted Air Cleaner • Muffler • Muffler Guard • 12 Volt Electric Starter Motor with 45 Amp External Alternator • Glow Plugs (Cold Start Aid) • Fuel Filter with valve • Mounting Feet • Mounted Control Panel • Also includes Safety shutdown for low oil pressure/high coolant temp 					
					
Standard Features Plus:					
<ul style="list-style-type: none"> • High Speed 3000 RPM • Suction Fan 					
• Group 5 housing and flywheel	ED3A76E0	KDW2204	KDW2204-1001	\$6,848.05	550
Standard Features Plus:					
<ul style="list-style-type: none"> • Low Speed 1800 RPM • Pusher Fan 					
• SAE 5 housing and 7 ½" flywheel	ED6A99E0	KDW2204	KDW2204-2001	\$6,848.05	550

Note: Orders will be filled with old spec number until stock is depleted.

**DIESEL LIQUID-COOLED
KDW2204T (4 Cylinder) 64.4 HP (48 kW)**

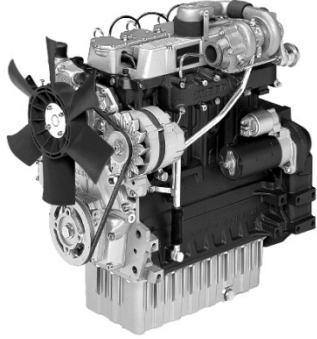
Description	Old Spec Number	Model	Spec. No.	List Price	Approx. Ship Wt. (lb.)
Standard Features:					
<ul style="list-style-type: none"> • Turbo charged • Mounted Top Tank Radiator • Radiator Fan Guard • Mounted Air Cleaner • Muffler • Muffler Guard • Suction Fan • 12 Volt Electric Starter Motor with 45 Amp External Alternator • Glow Plugs (Cold Start Aid) • Fuel Filter with valve • Mounting Feet • Mounted Control Panel • Also includes Safety shutdown for low oil pressure/high coolant temp. 					
					
Standard Features Plus:					
• High Speed 3000 RPM					
• Group 5 housing and flywheel		KDW2204T	KDW2204T-1001	\$7,771.69	576
Standard Features Plus:					
• Low Speed 1800 RPM					
• Pusher Fan					
• SAE 5 housing and 7 ½" flywheel	ED6B21E1	KDW2204T	KDW2204T-2001	\$7,771.69	576
Note: Orders will be filled with old spec number until stock is depleted.					

**EVAP Cross Reference
Courage and Command Basic Engines**

Model	HP	Old Spec No.	EVAP Spec No.
CH18	18	62500	CH620-3002
CH18	18	62501	CH620-3003
CH18	18	62502	CH620-3005
CH18	18	62503	CH620-3004
CH18	18	62504	CH620-3007
CH18	18	62505	CH620-3009
CH18	18	62506	CH620-3008
CH18	18	62507	CH620-3006
CH18	18	62587	CH620-3053
CH20	20	64500	CH640-3006
CH20	20	64501	CH640-3002
CH20	20	64503	CH640-3004
CH20	20	64594	CH640-3007
CH20	20	64595	CH640-3008
CH20	20	64672	CH640-3005
CH23	23	76501	CH680-3002
CH23	23	76601	CH680-3001
CH730	25	CH730-0001	CH730-3200
CH730	25	CH730-0002	CH730-3205
CH730	25	CH730-0038	CH730-3038
CH730	25	CH730-0039	CH730-3201
CH730	25	CH730-0040	CH730-3203
CH730	25	CH730-0041	CH730-3202
CH730	25	CH730-0108	CH730-3210
CH730	25	CH730-3038	CH730-3208
CH730	25	CH730-3039	CH730-3209
CH730	25	CH730-3040	CH730-3203
CH730	25	CH730-3131	CH730-3206
CH730	25	CH730-3217	CH730-3207
CH740	27	CH740-0001	CH740-3002
CH740	27	CH740-0002	CH740-3003
CH740	27	CH740-0004	CH740-3004
CH740	27	CH740-0012	CH740-3006
CH740	27	CH740-0013	CH740-3005
CH740	27	CH740-0060	CH740-3007
CH740	27	CH740-3001	CH740-3101
CH740	27	CH740-3012	CH740-3009
CH740	27	CH740-3135	CH740-3008
CH745	28	CH745-0010	CH745-3100
CH750	30	CH750-0005	CH750-3005
CH750	30	CH750-0006	CH750-3006
CH750	30	CH750-0007	CH750-3007
CH750	30	CH750-0008	CH750-3000
CH750	30	CH750-0009	CH750-3009

**EVAP Cross Reference
Courage and Command Basic Engines**

Model	HP	Old Spec No.	EVAP Spec No.
CH940	34	CH940-0002	CH940-2002
CH940	34	CH940-0003	CH940-2003
CH940	34	CH940-0005	CH940-2005
CH960	36	CH960-0002	CH960-2002
CH960	36	CH960-0003	CH960-2003
CH980	38	CH980-0002	CH980-2002
CH980	38	CH980-0003	CH980-2003
CH980	38	CH980-0005	CH980-2005
CH1000	40	CH1000-0002	CH1000-2002
CH1000	40	CH1000-0012	CH1000-2012
CV18	18	61500	CV620-3001
CV20	20	65500	CV640-3001
CV23	23	75500	CV680-3001
CV23	23	75550	CV680-3002
CV730	25	CV730-0001	CV730-3101
CV740	27	CV740-0001	CV740-3001
CV750	30	CV750-0005	CV750-3005
CV940	34	CV940-0002	CV940-2002
CV960	36	CV960-0002	CV960-2002
CV980	38	CV980-0002	CV980-2002
SV480	16	SV480-0200	SV480-3200
SV540	18	SV540-0202	SV540-3202
SV600	20	SV600-0202	SV600-3202
SV610	21	SV610-0200	SV610-3200
SV620	22	SV620-0202	SV620-3202
SV725	24	SV725-0002	SV725-3002
SV735	26	SV735-0002	SV735-3002

KOHLER[®] ENGINES

FOR SALES AND SERVICE INFORMATION
IN U.S. AND CANADA, CALL **1-800-544-2444**

KohlerEngines.com

ENGINE DIVISION, KOHLER CO., KOHLER, WISCONSIN 53044

© 2010 by Kohler Co. All rights reserved.

FORM NO.:	TP-2389-T
ISSUED:	11/10
REVISED:	



1PTP-2389-T



6 50531 91706 5